



LCI(L)1-349 CLASS US VERSION

The LCI(L) for Landing Craft Infantry (Large) was the result of a request from the Royal Navy asking for a sea going vessel able to land large numbers of infantry (up to 200 troops) directly onto the beaches.

The British naval shipyards being fully committed to build warships, the complete series of 923 LCI(L)s was constructed in the USA between 1942 and 1944. The LCI(L) was built in three different classes:

- LCI(L)-1 to LCI(L)-350 had square superstructures, small bridge for the UK version, tall one for the US Navy one, both have side ramps to disembark troops.

- From LCI(L)-351 to LCI(L)-1098 two sub-classes can be found.

- LCI(L)-351 à 640, 658-690, 708-761, 781, 822-865, 885-1023, 1034-1067 still have side ramps, but superstructures are more rounded with a different 20mm arrangement.

- LCI(L)-641 à 657, 691-707, 762-780, 782-821, 866-884, 1024-1033, and 1068-1098 have the same configuration, but have now a bow ramp with doors for a better troops protection.

LCI(L)s were of all the major amphibious operations during WWII, from the European Theater to the shores of Pacific Islands. Today two surviving examples have been preserved in the USA: LCI(L)-713 in Portland, Oregon, and LCI(L)-1091 in Eureka, California.

LCI(L)s were of all the major amphibious operations during WWII, from the European Theater to the shores of Pacific Islands. Today two surviving examples have been preserved in the USA: LCI(L)-713 in Portland, Oregon, and LCI(L)-1091 in Eureka, California.

Le LCI(L), pour Landing Craft Infantry (Large) fut développé à la demande de la Royal Navy qui recherchait un bâtiment capable de transporter 200 soldats des côtes anglaises jusqu'aux plages de débarquement. Plus grand que le LCA alors en service, le LCI(L) fut produit aux USA, les chantiers britanniques étant alors pleinement occupés par la construction de destroyers et autres navires de guerre.

PARTS

MAIN PARTS

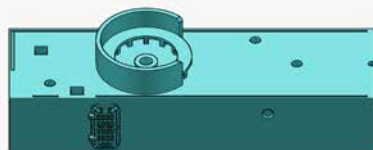
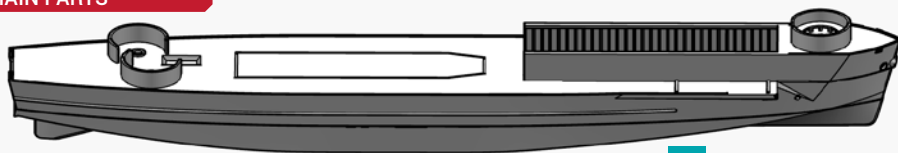

DETAIL PARTS

BAR A

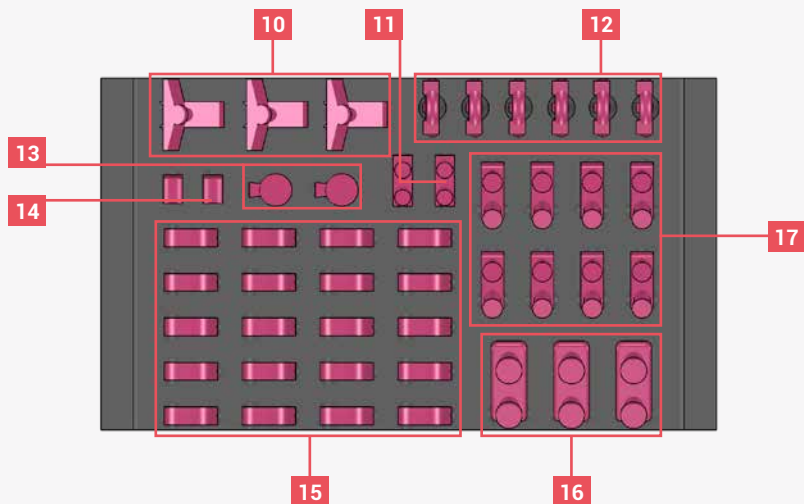
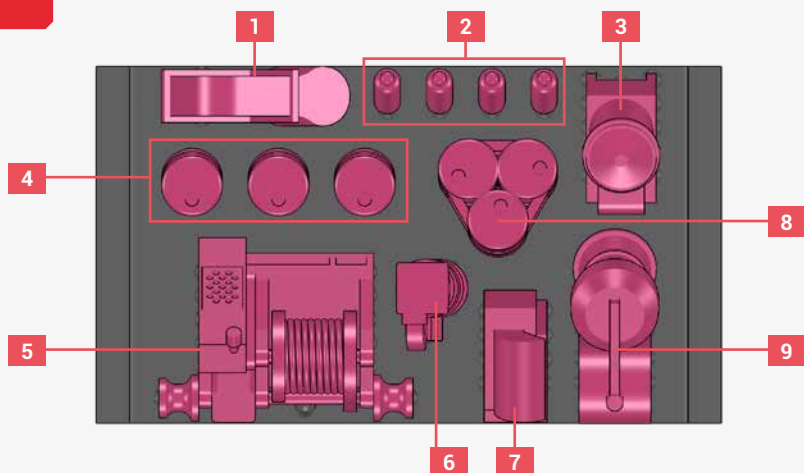

BAR B

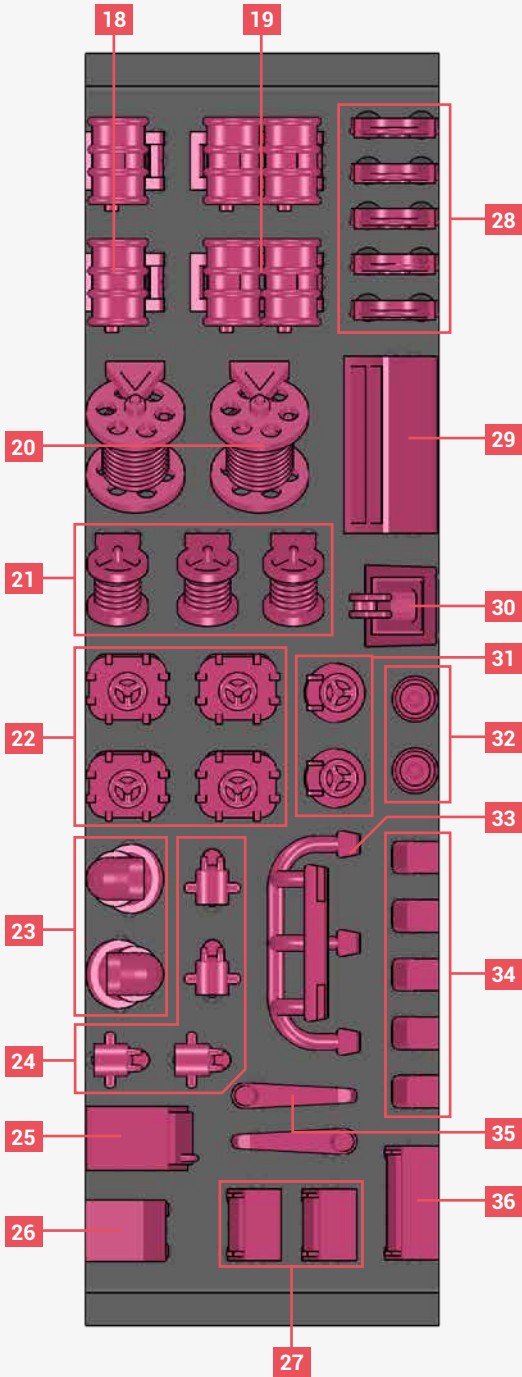

BAR C

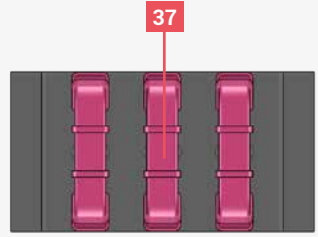

BAR D

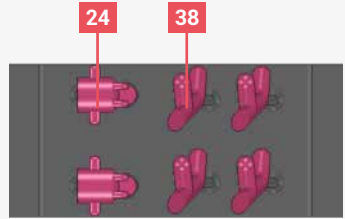

BAR E

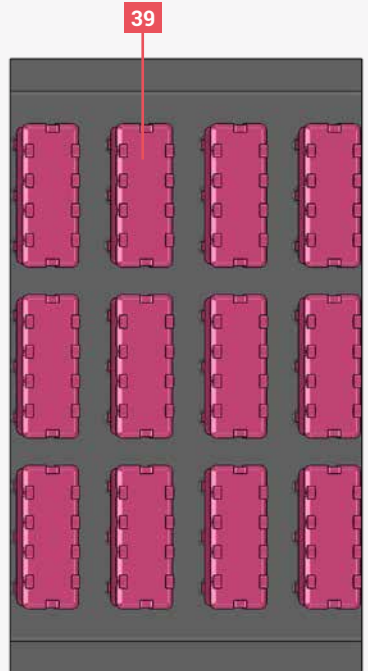

BAR F

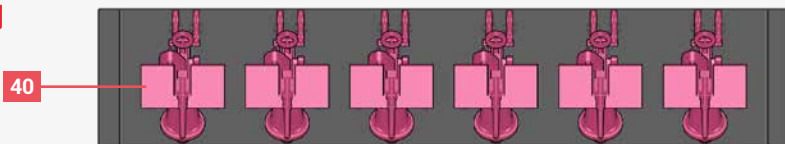

BAR G

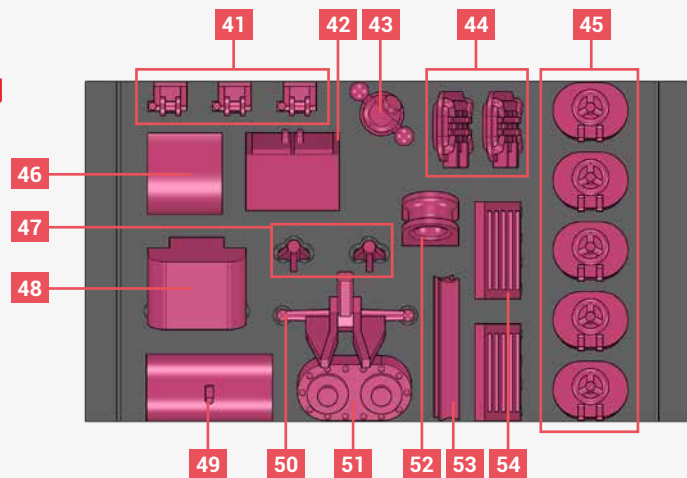

BAR H

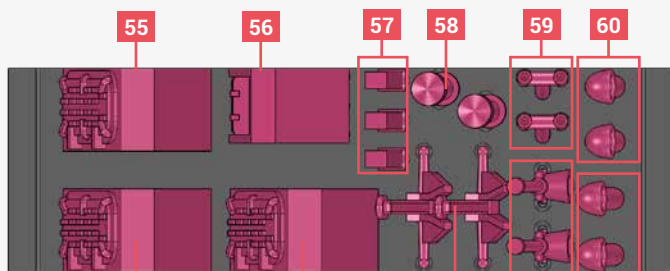

BAR I

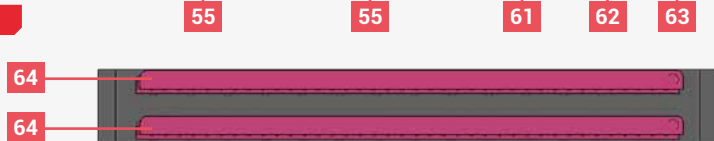

BAR J

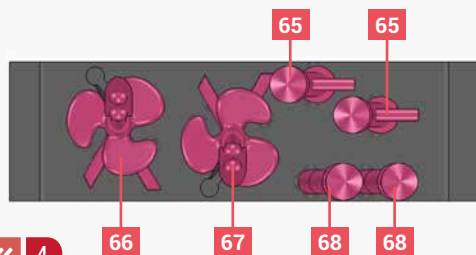

BAR K

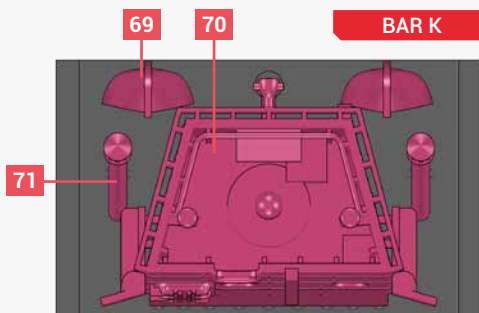

BRASS PARTS

A	x1	Ø=0.3MM L=14MM
B	x1	Ø=0.5MM L=28MM

PHOTOETCH PARTS

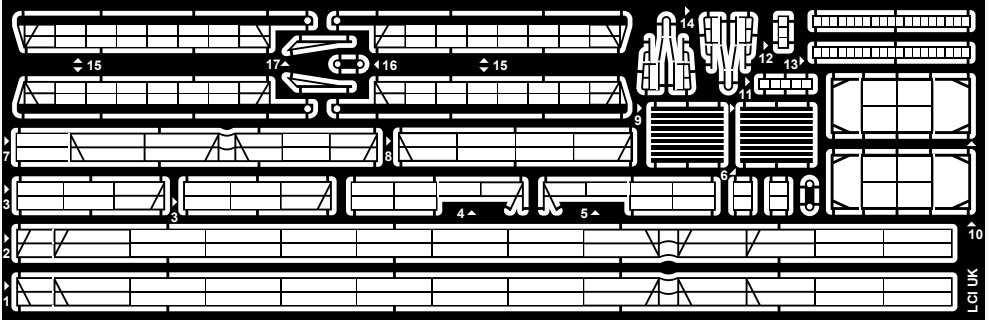

DECALS PARTS

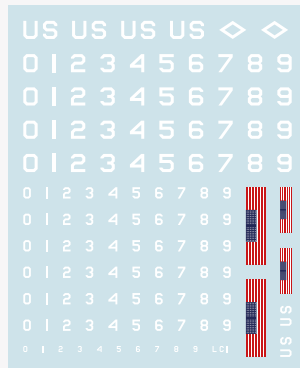

INSTRUCTION NOTES

XX	RESIN PARTS
XX	3D PARTS
XX	PHOTOETCH PARTS
XX	BRASS PARTS
XX	DECALS PARTS

!	ASSEMBLY WARNING
PS	PORT & STARBOARD
P	PORT SIDE
S	STARBOARD SIDE
X	INFORMATIONS

SOME PHOTOETCH AND 3D PARTS ARE PROVIDED IN EXTRA NUMBERS.

IMPORTANT ! PLEASE FULLY READ THE INSTRUCTIONS BEFORE STARTING THE BUILD !

STEP 1

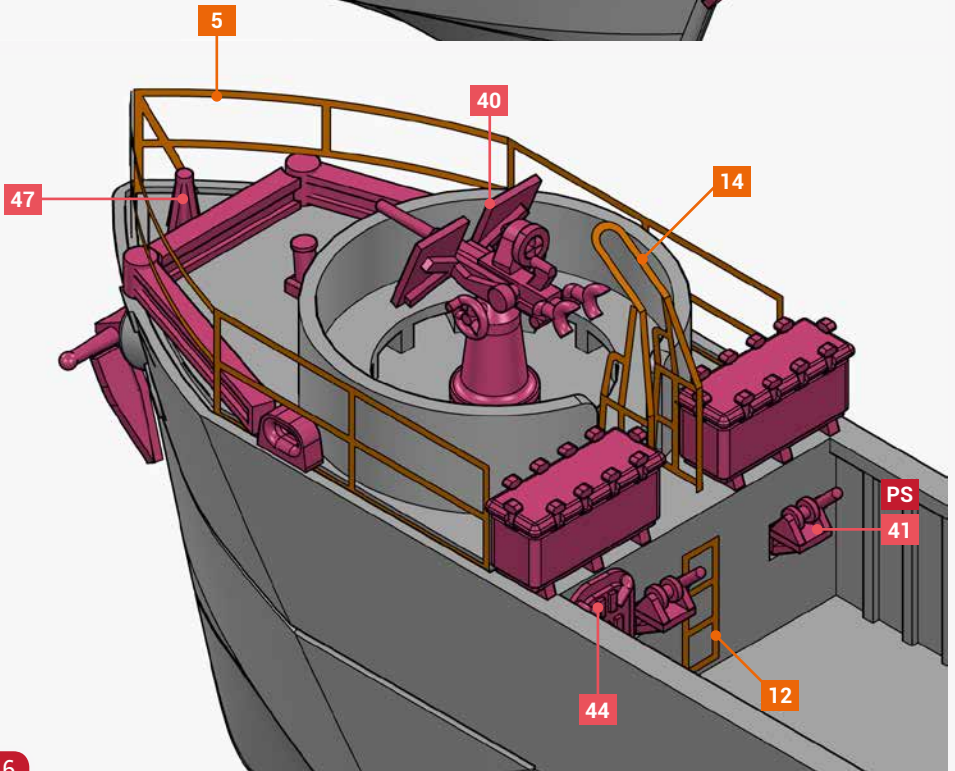
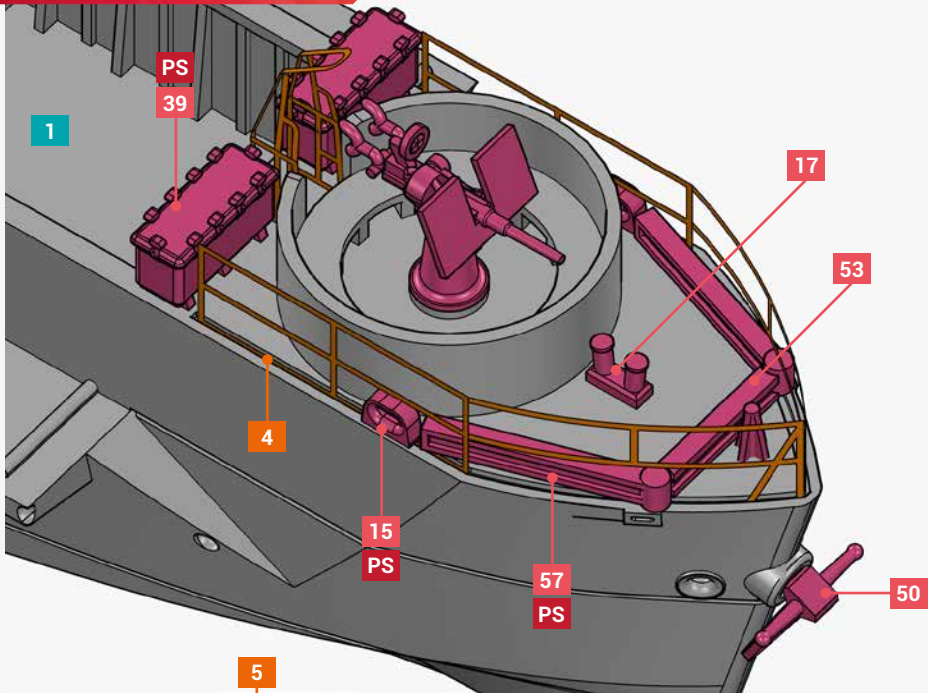

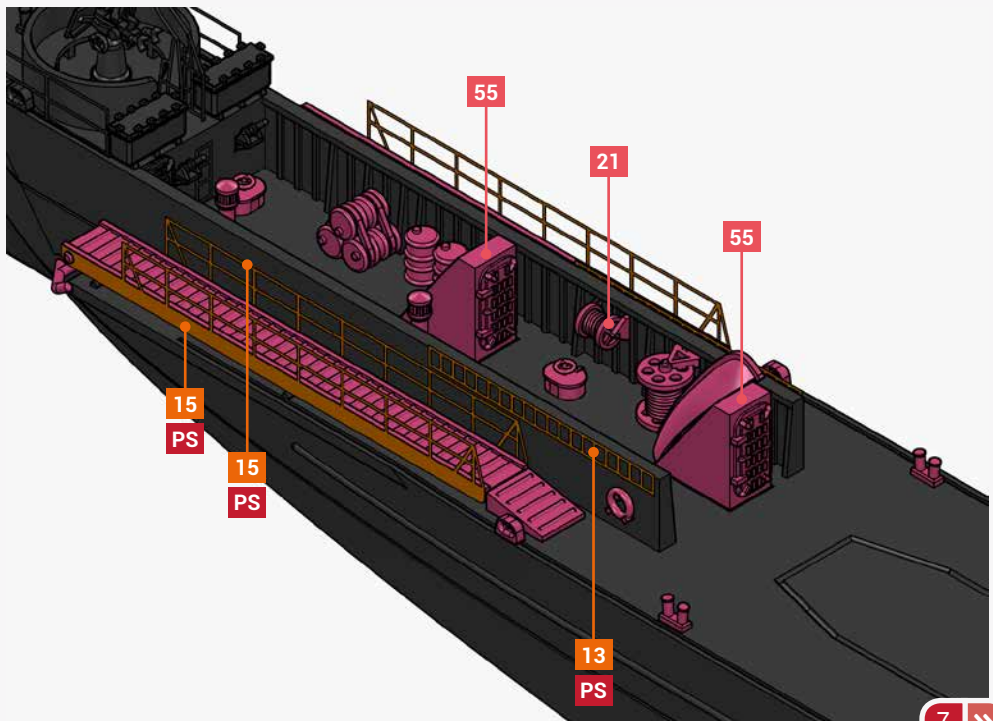
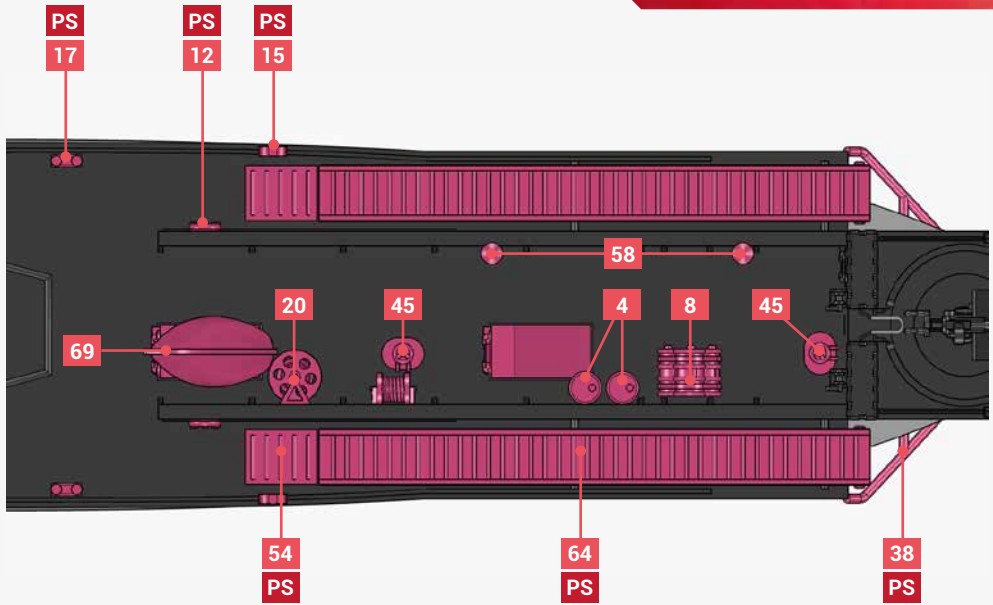

STEP 3

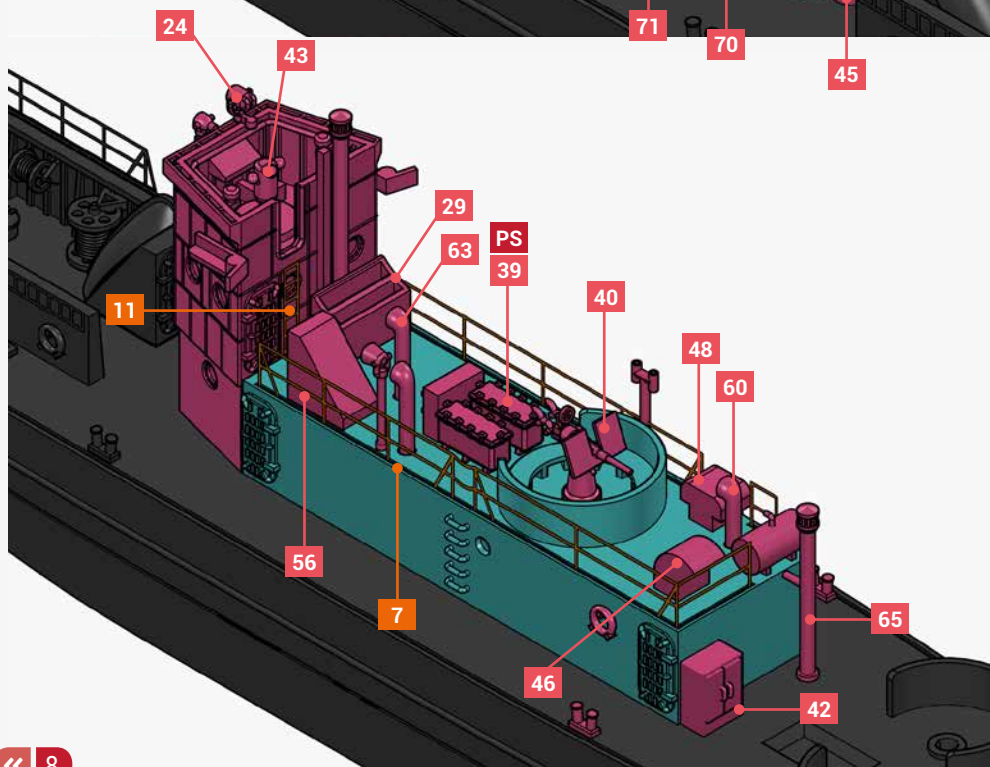
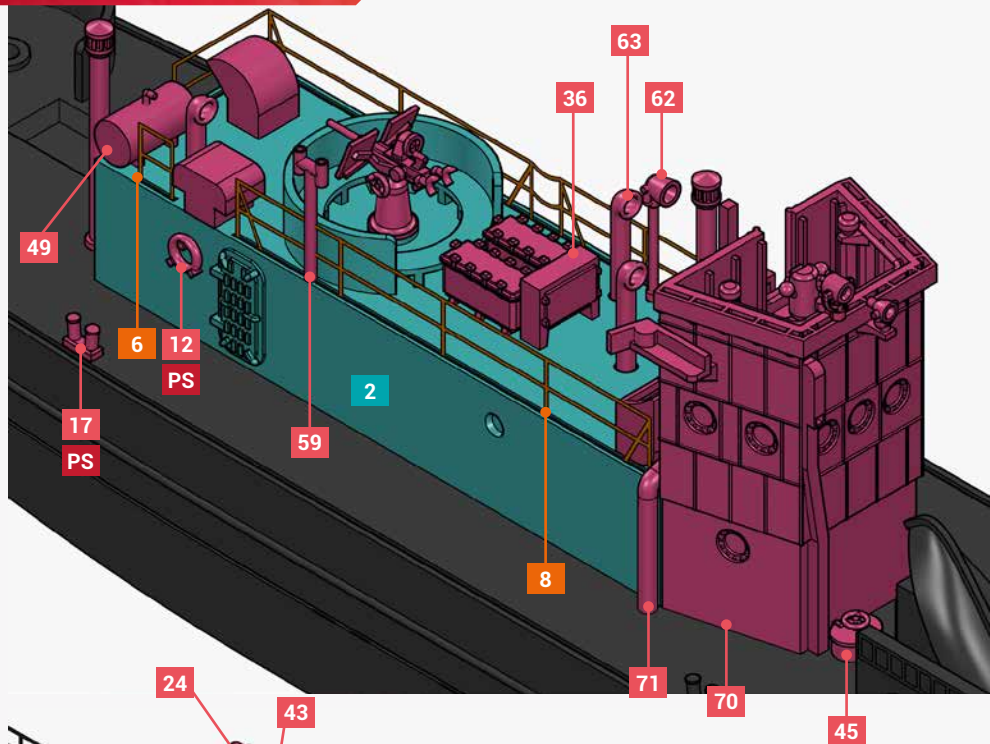

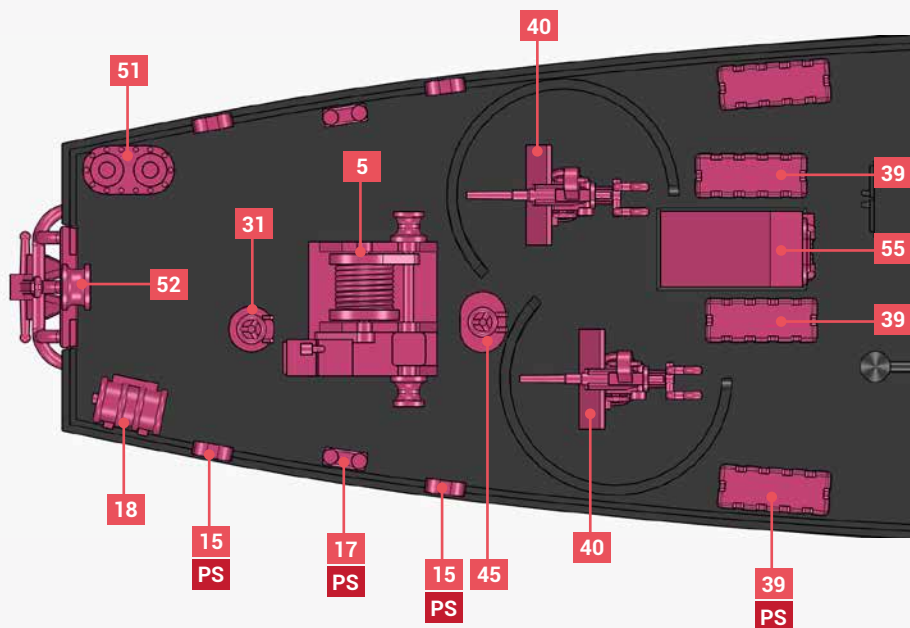
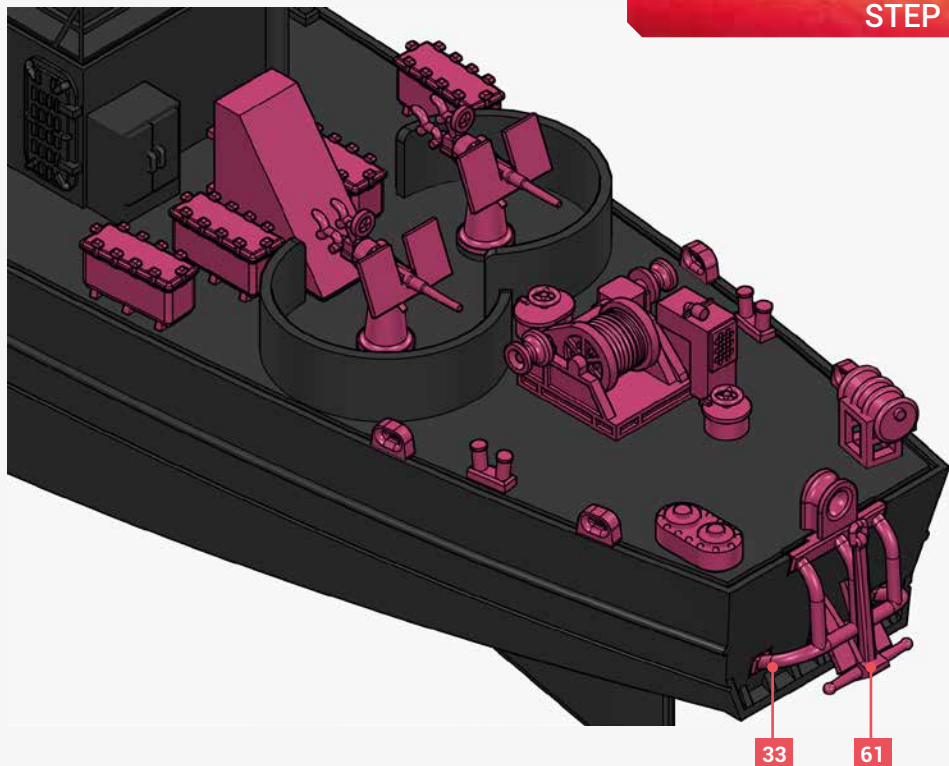

STEP 5

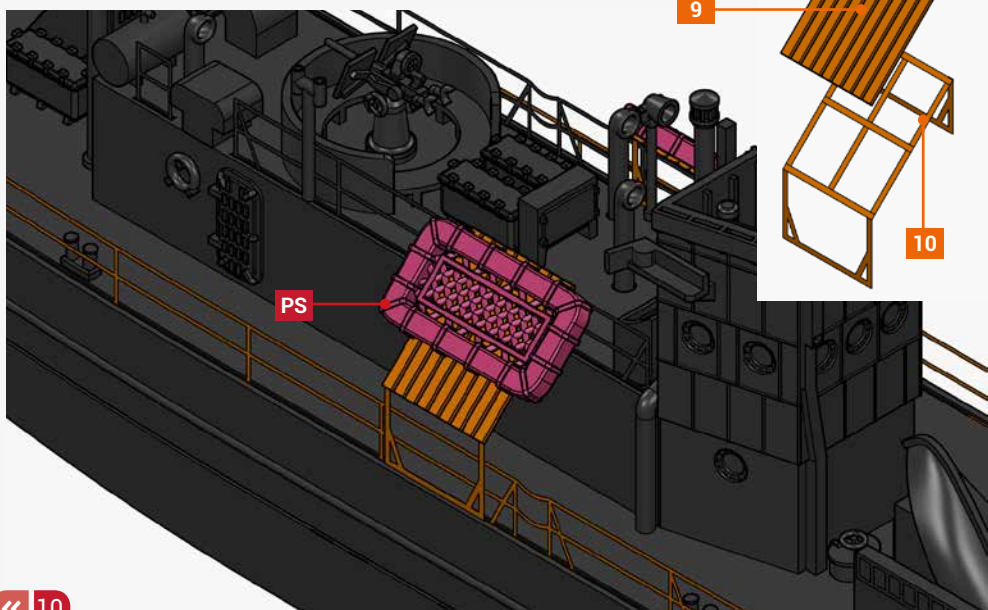
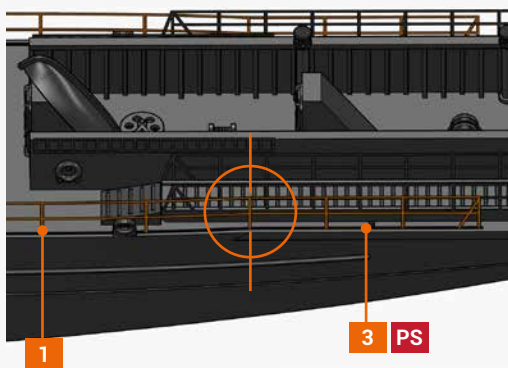
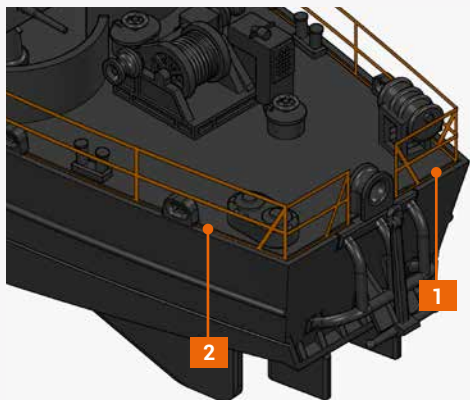
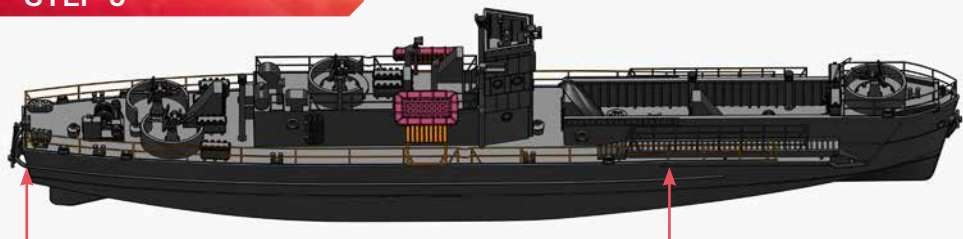

STEP 6

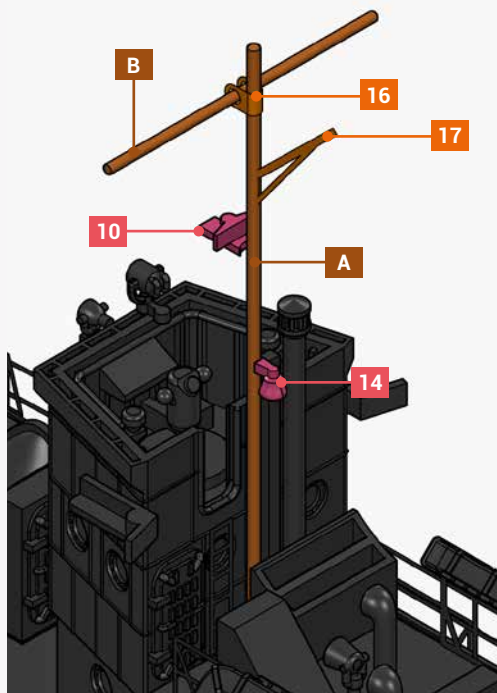
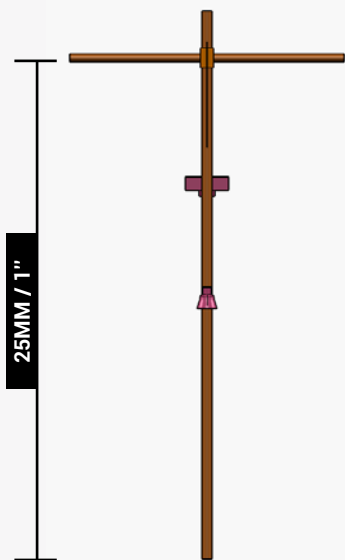

STEP 7

