



HMS/FNFL MIMOSA K11 FLOWER CLASS CORVETTE

When the battle for convoys started in the Atlantic Ocean, Royal Navy was desperately short of escorts to protect the cargo ships against U-boat attacks. An emergency solution was to adapt the design of a whaler into an escort, which led to the birth of the famous Flower class corvettes. First units had a modest armament consisting of a 4-inch gun on the forecastle, a single 40mm pompom amidships and two twin Lewis machine guns on each side of the bridge. ASW armament consisted of four Mk.II depth charges throwers and two depth charges rails on stern. Although handicapped by their low speed of 16 knots, the 294 Flowers that were built bore the brunt of the battle until mid-1943, when new classes of escorts, such as the Rivers and US Destroyer Escorts, began to be available.

HMS Mimosa was laid down on April 22, 1940 at Charles Hill & Sons in Bristol, England and launched on January 18, 1941. She was transferred to the Free French Navy on May 11, 1941. FNFL Mimosa had a short wartime career. She was sunk by U-124 on June 9, 1942, while escorting Convoy ONS-100. A total of 58 French and 6 British sailors were killed. HMCS Assiniboine rescued 4 survivors.

XX	RESIN PARTS
XX	3D PARTS
XX	PHOTOETCH PARTS
XX	BRASS PARTS
XX	DECALS PARTS

!	ASSEMBLY WARNING
PS	PORT & STARBOARD
P	PORT SIDE
S	STARBOARD SIDE
X	INFORMATIONS

SOME PHOTOETCH AND 3D PARTS ARE PROVIDED IN EXTRA NUMBERS.

IMPORTANT ! PLEASE FULLY READ THE INSTRUCTIONS BEFORE STARTING THE BUILD !

DECALS

KI8I KI8I KI8I ♣ KII
 KI66 KI66 KI66 KII
 KI66 KI66 KI66 KII
 K0123456789
 K0123456789
 K0123456789
 K0123456789
 K0123456789
 K0123456789
 K0123456789
 K0123456789



SOME 3D AND BRASS PARTS ARE PROVIDED TO CONSTRUCT AN ALTERNATE VERSION OF THE SHIPS.

PHOTOETCH

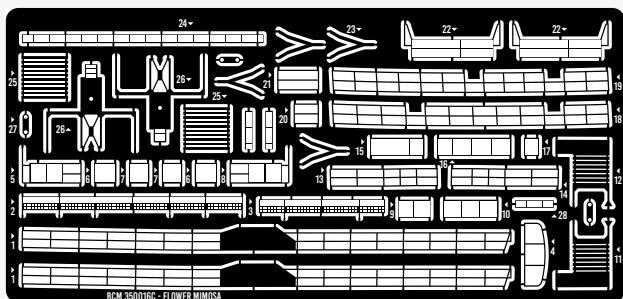

BRASS

A	x1	Ø=0.83MM L=42MM
B	x6	Ø=0.4MM L=4MM
C	x1	Ø=0.4MM L=10MM
D	x1	Ø=0.4MM L=13MM

PARTS

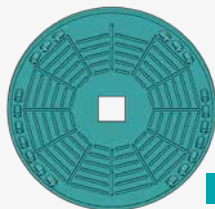
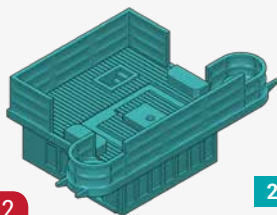
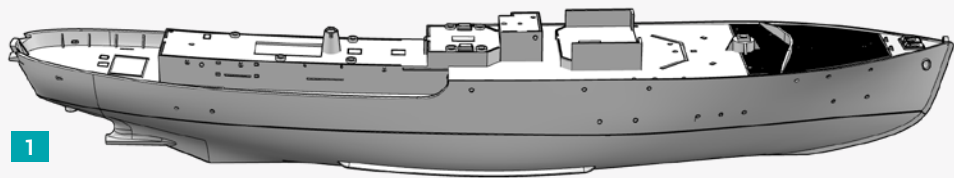

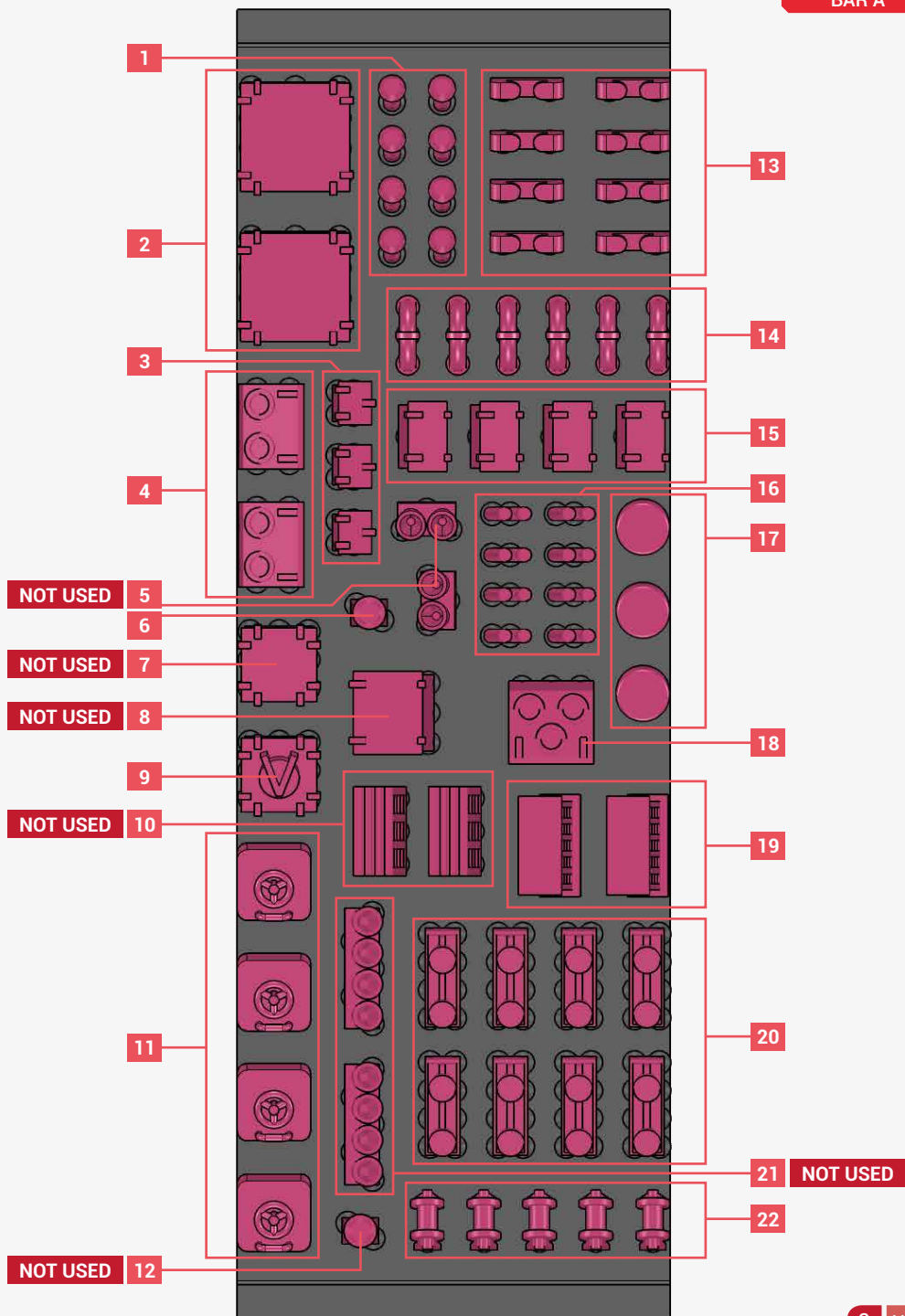

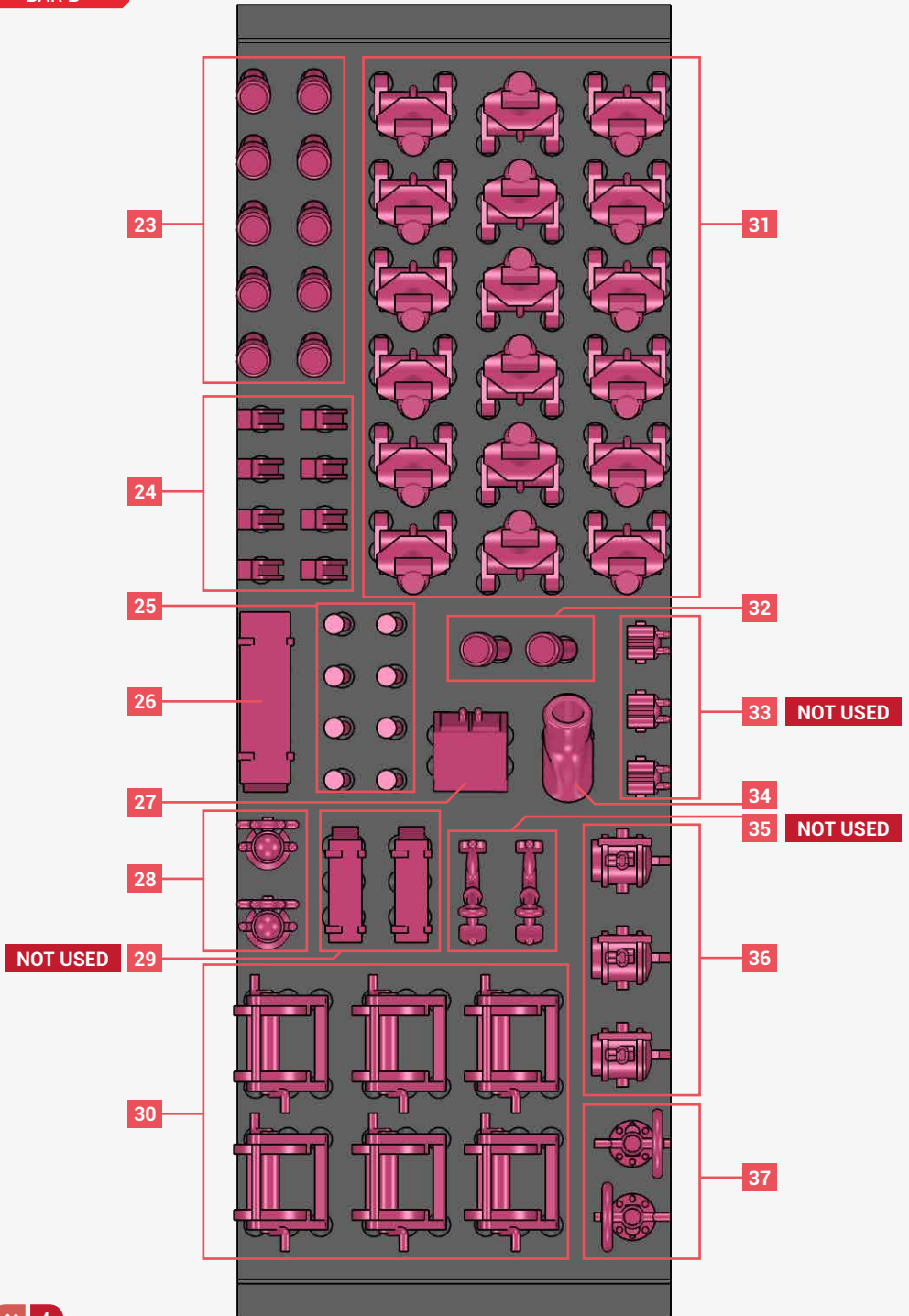

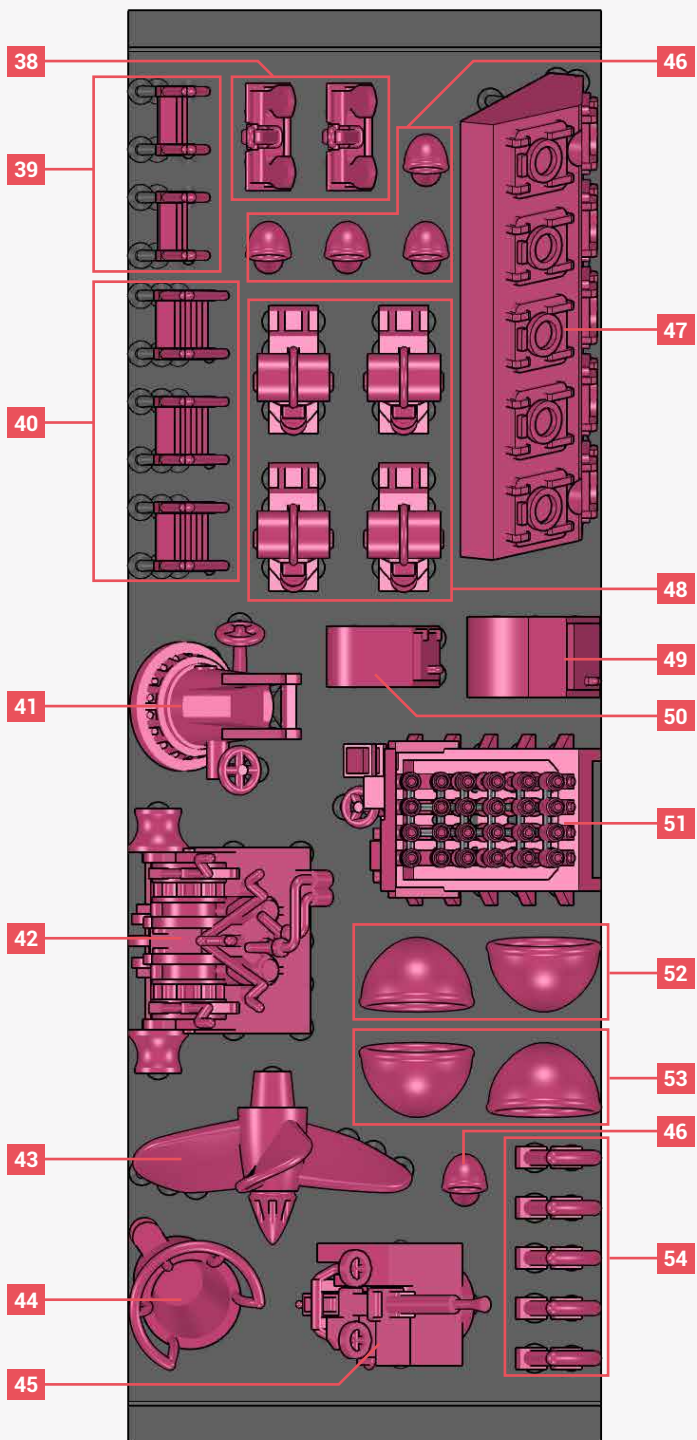

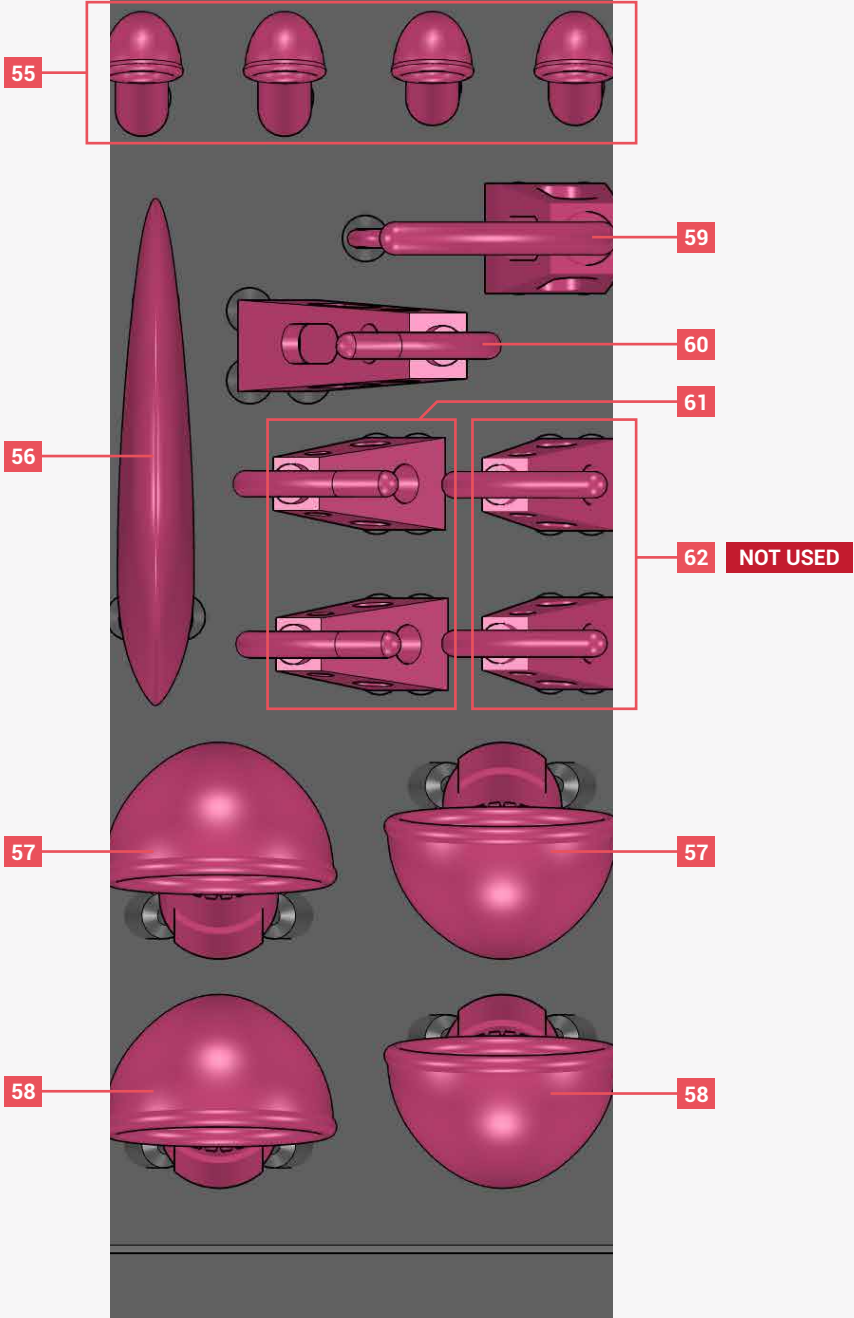

BAR E

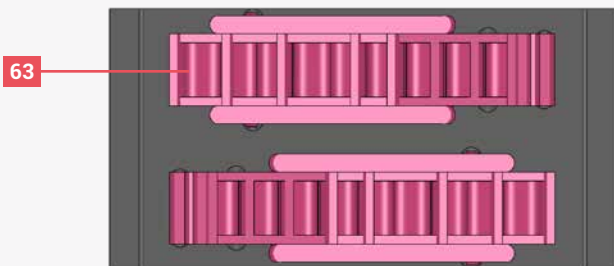

BAR F

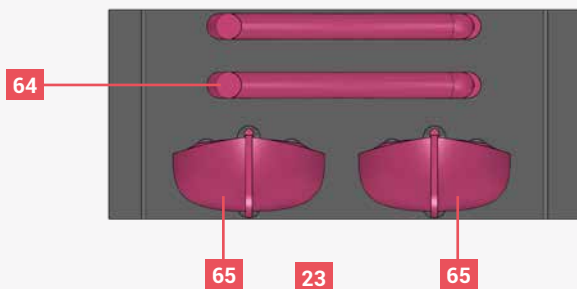

BAR G

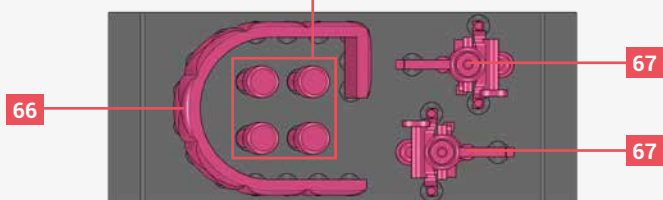

BAR H

NOT USED

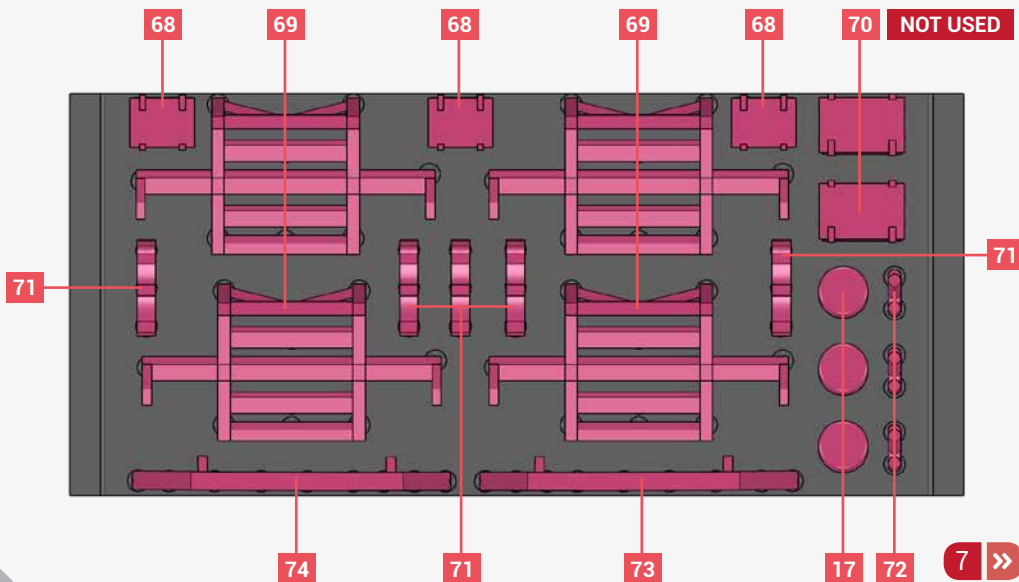

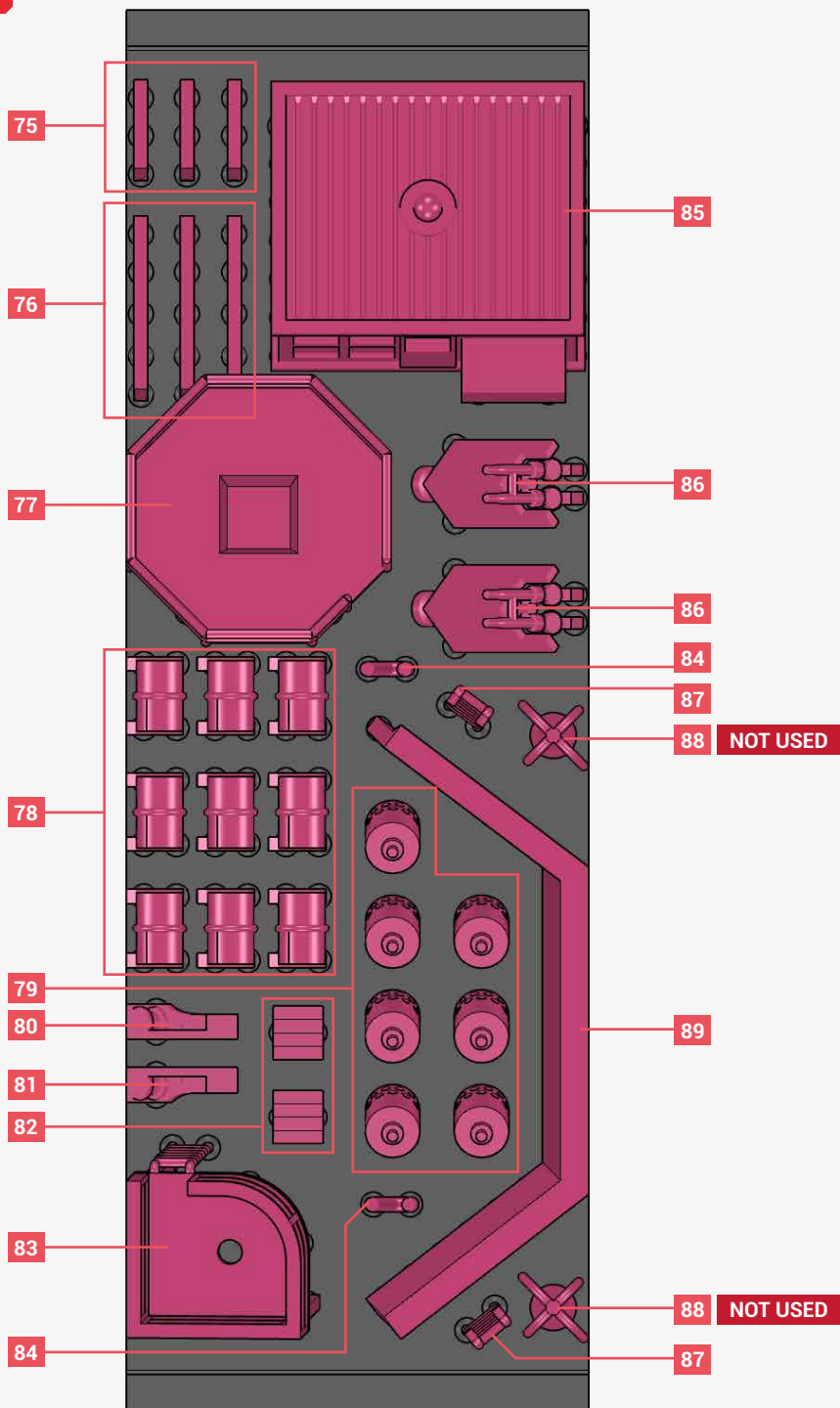

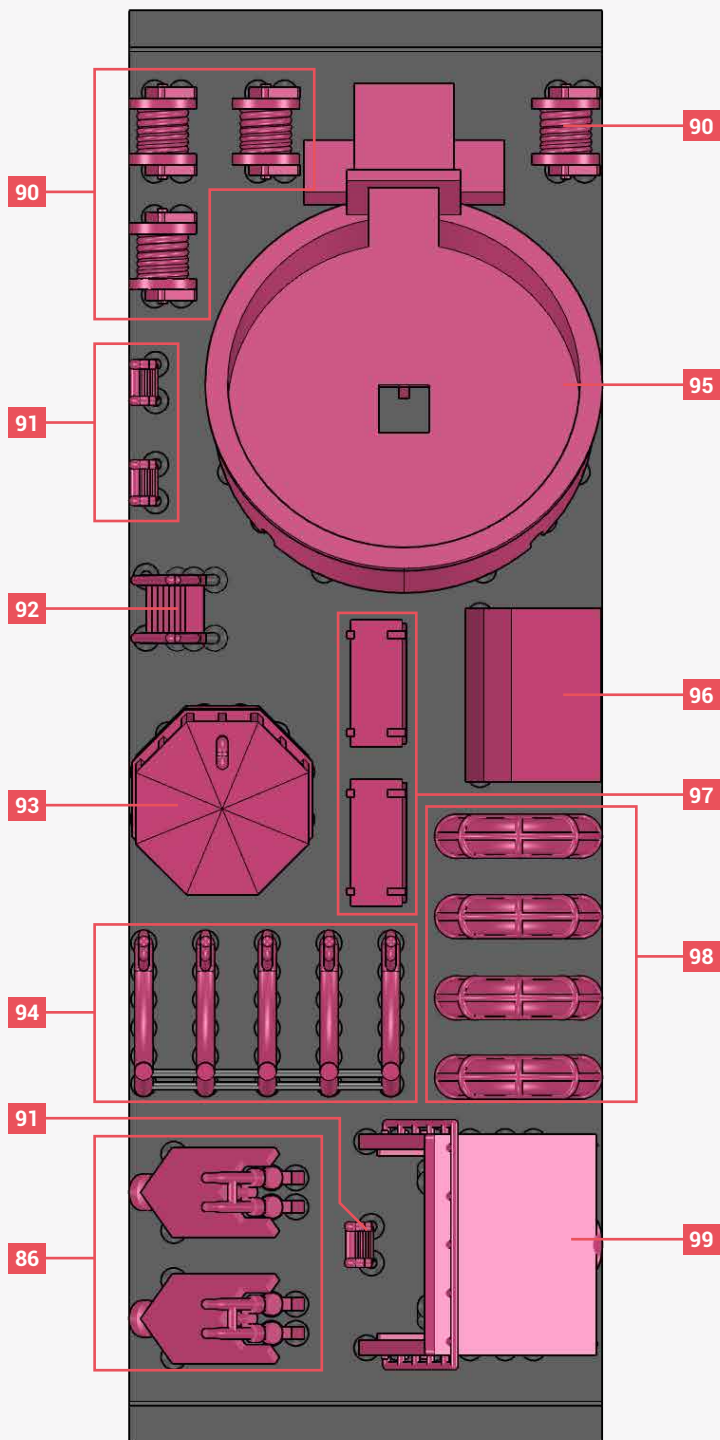

STEP 1

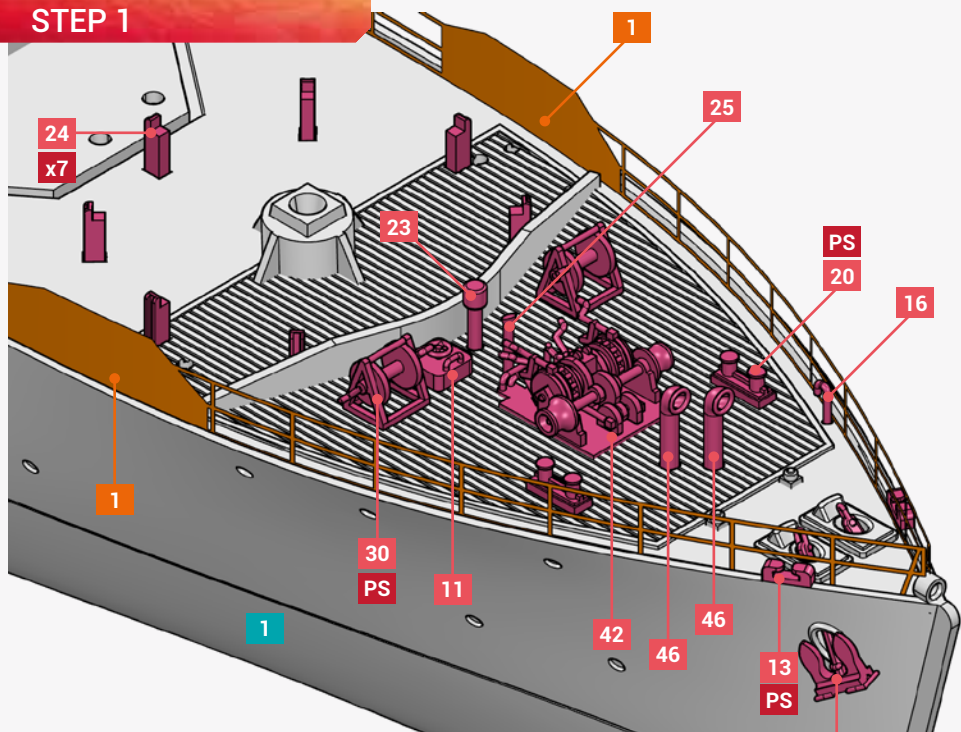

STEP 2

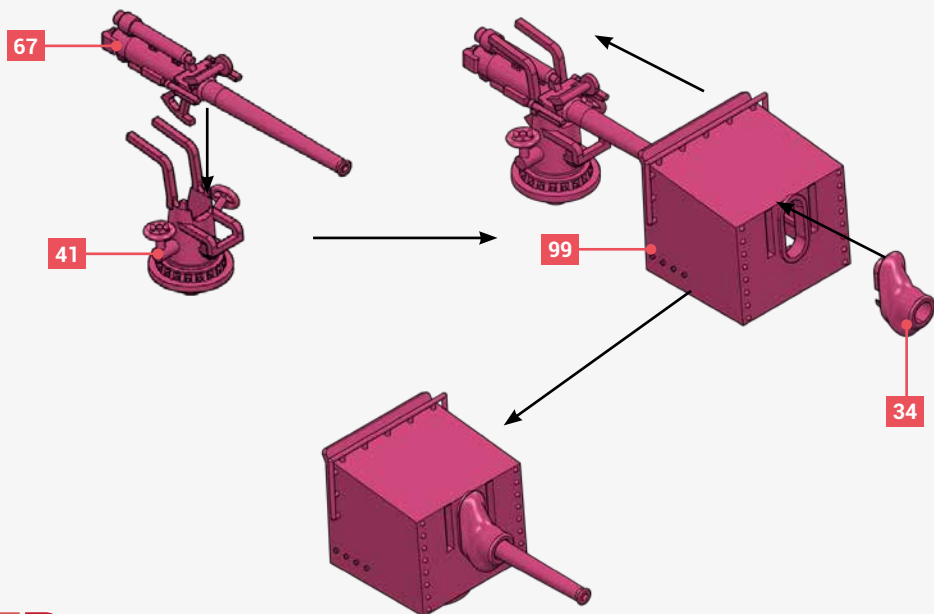

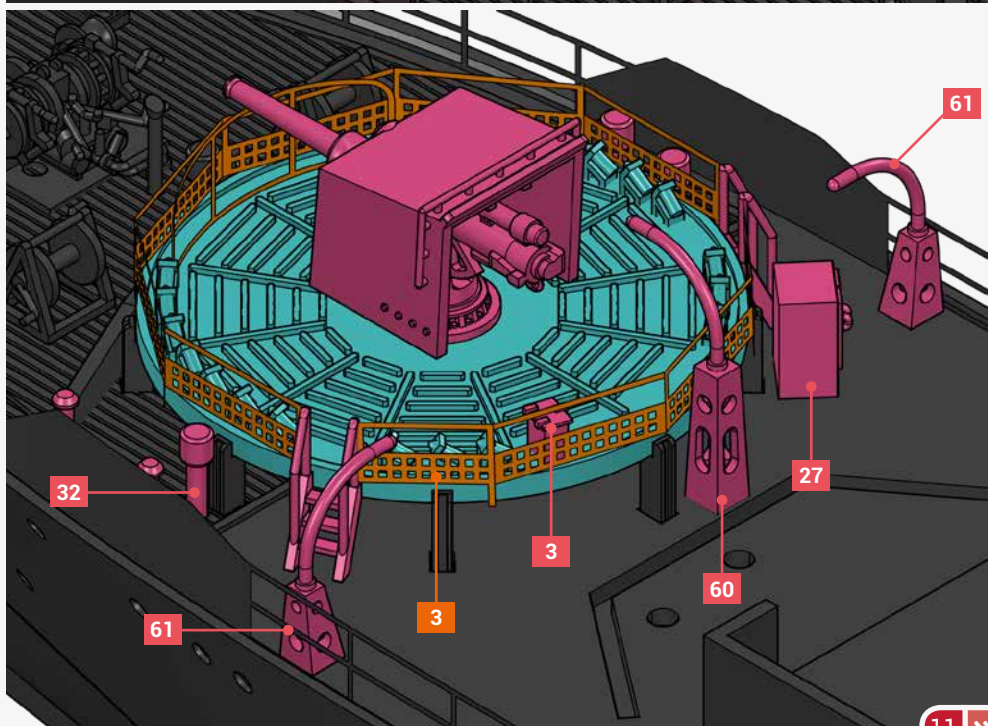
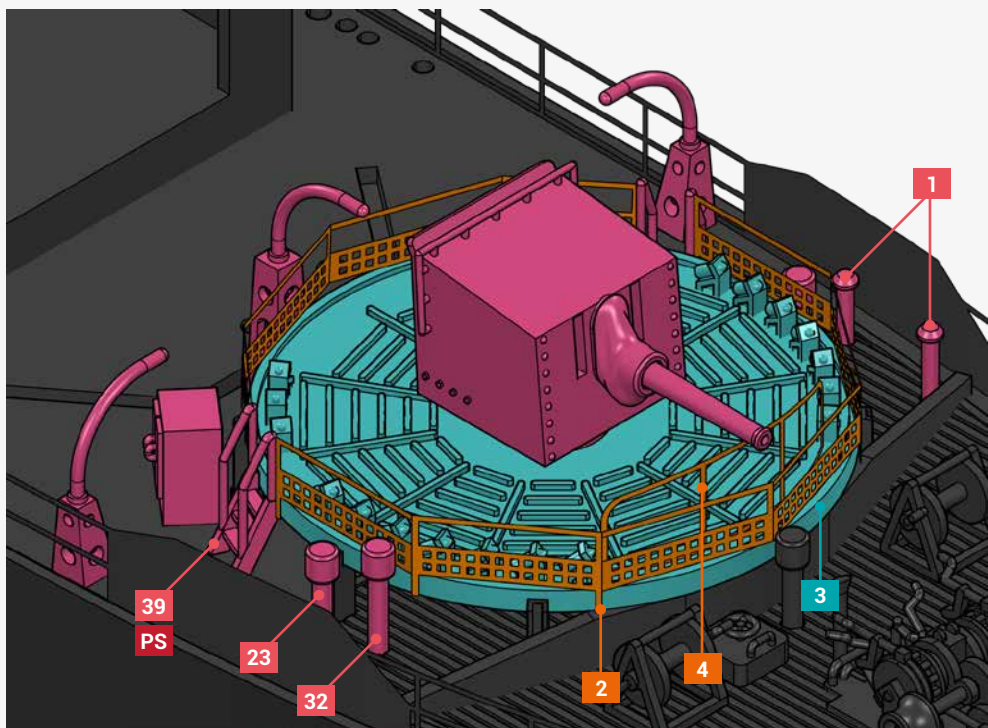

STEP 3

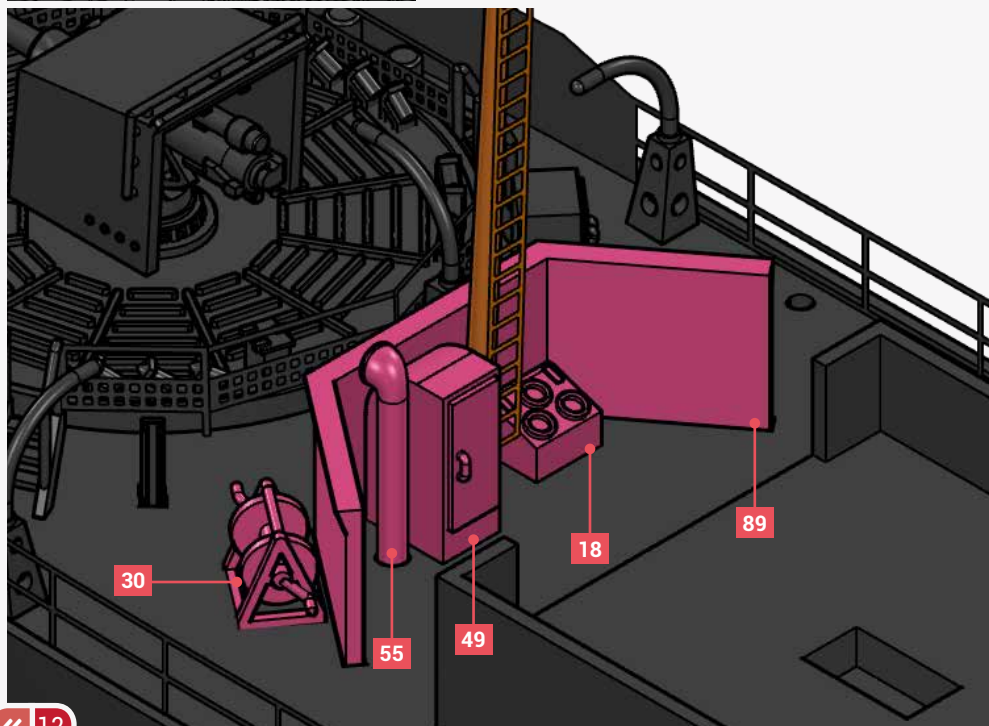
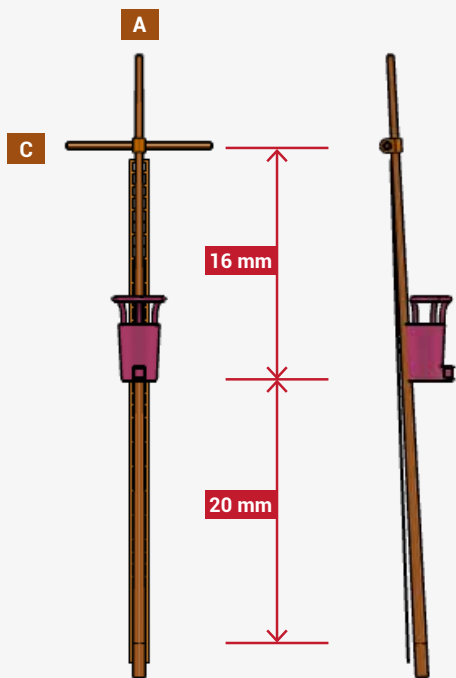
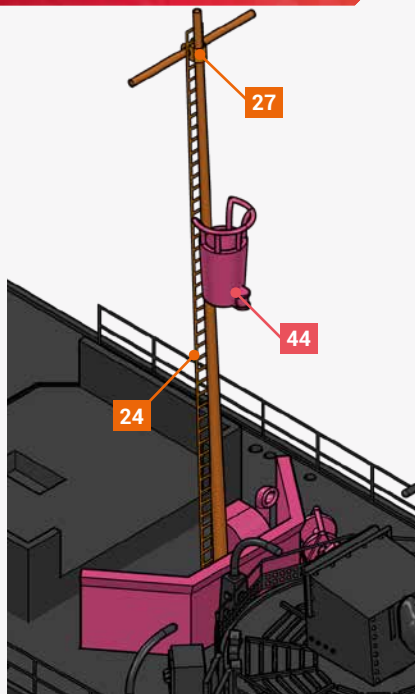

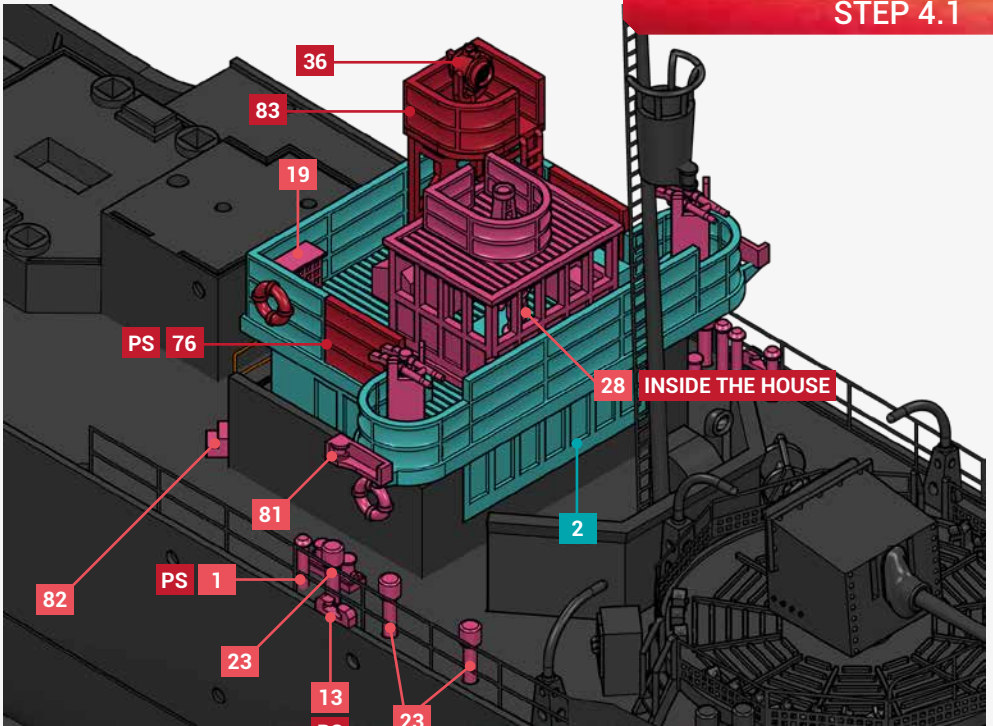

MIMOSA VERSION PARTS

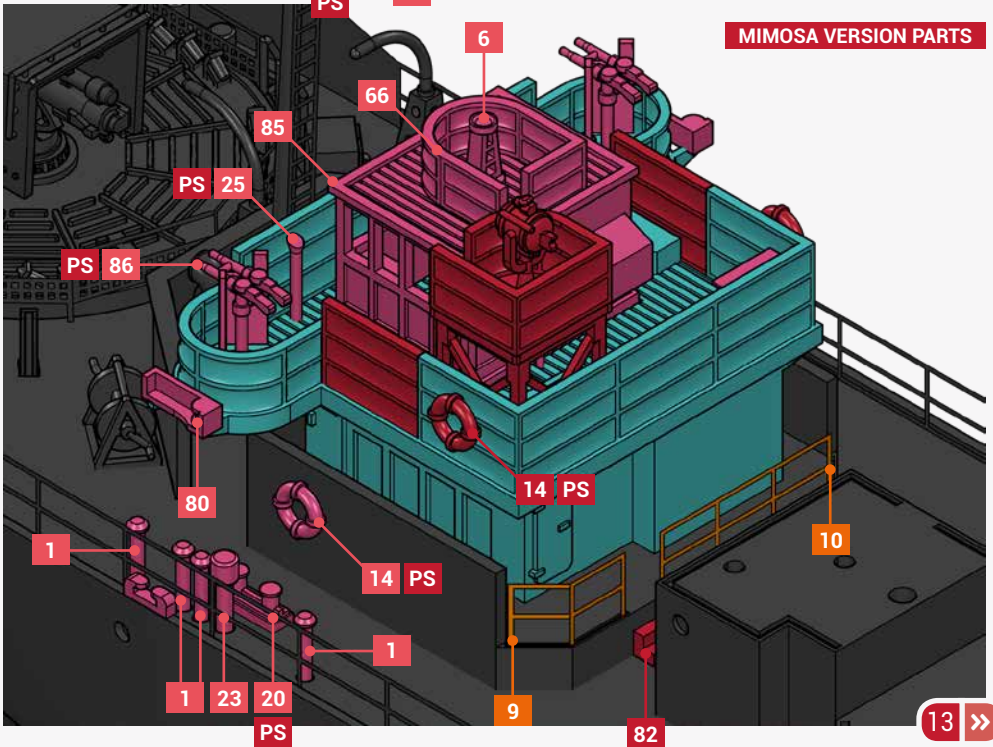

STEP 4.2

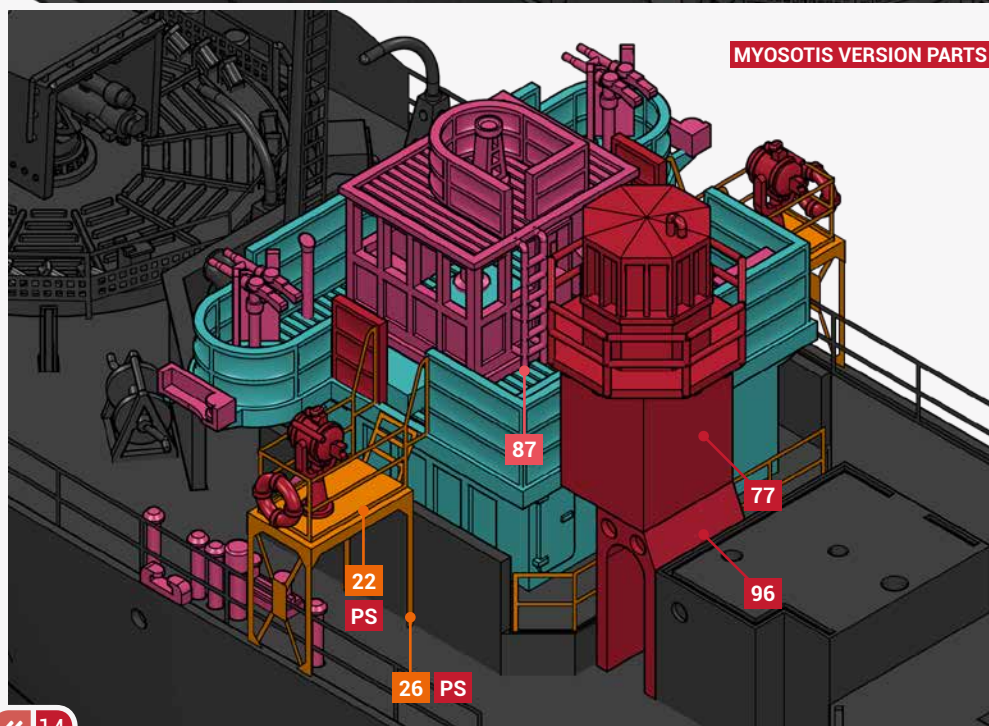
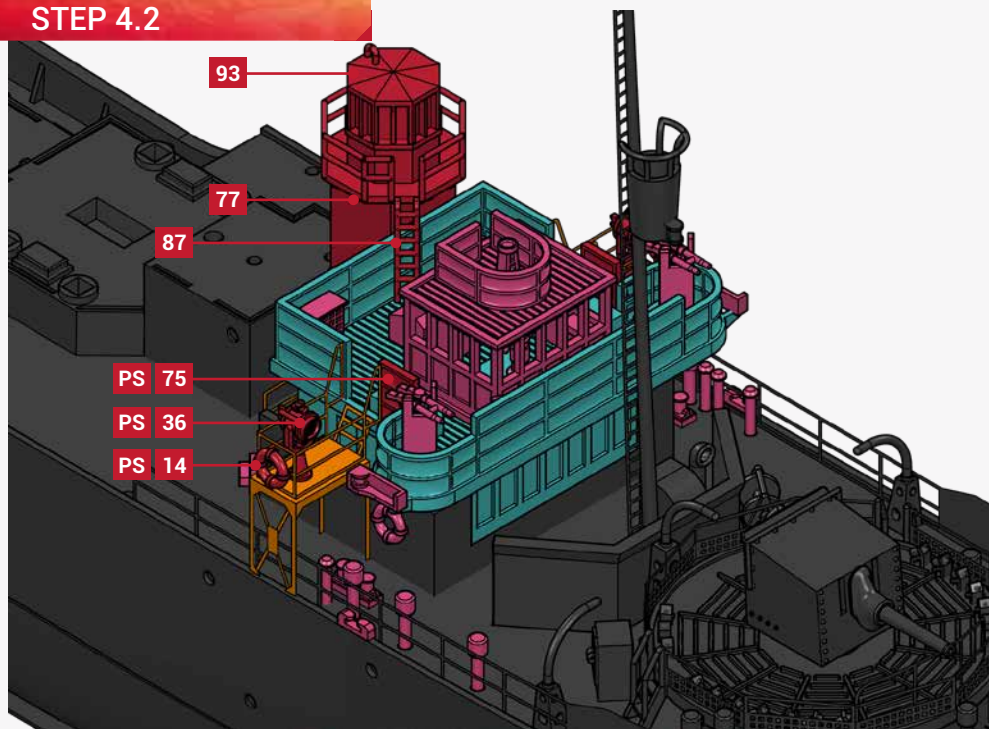

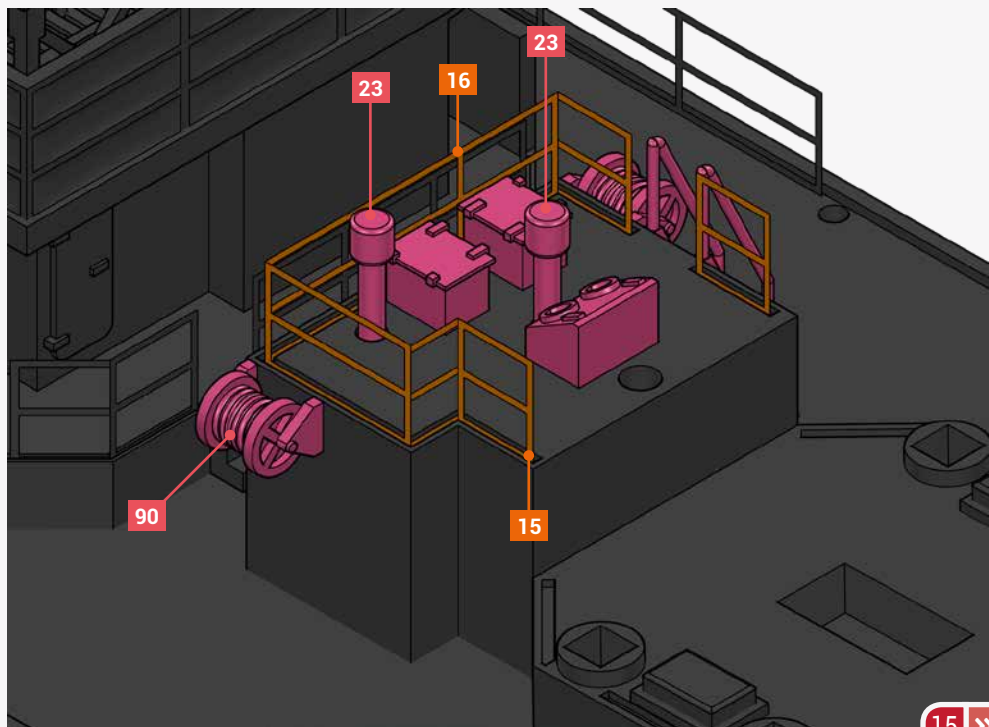
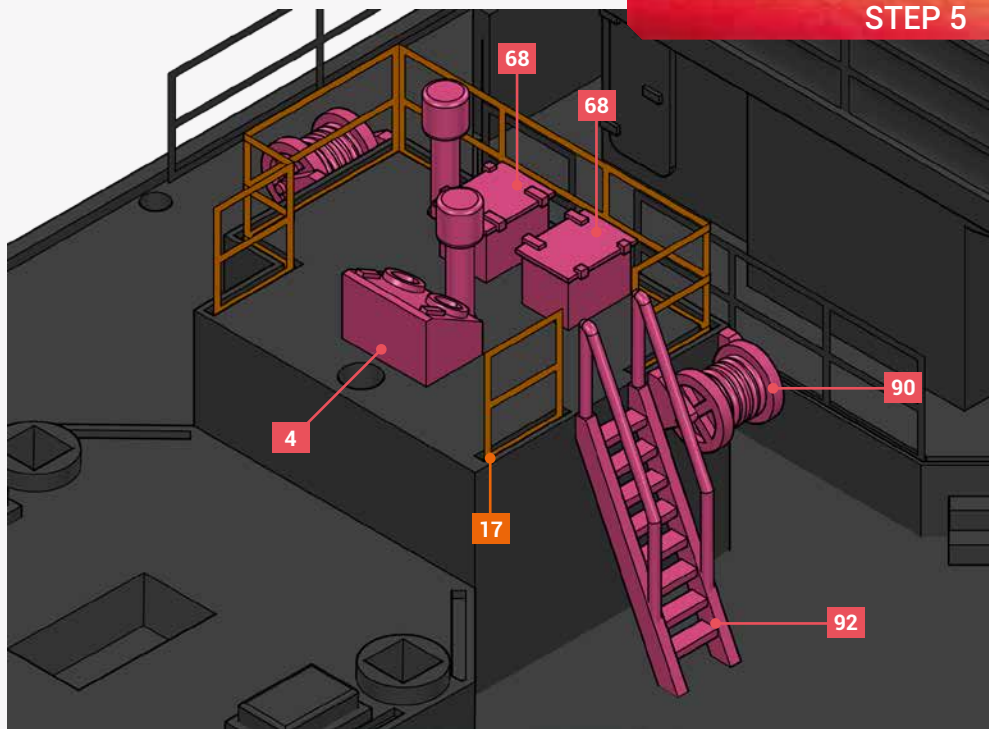

STEP 6

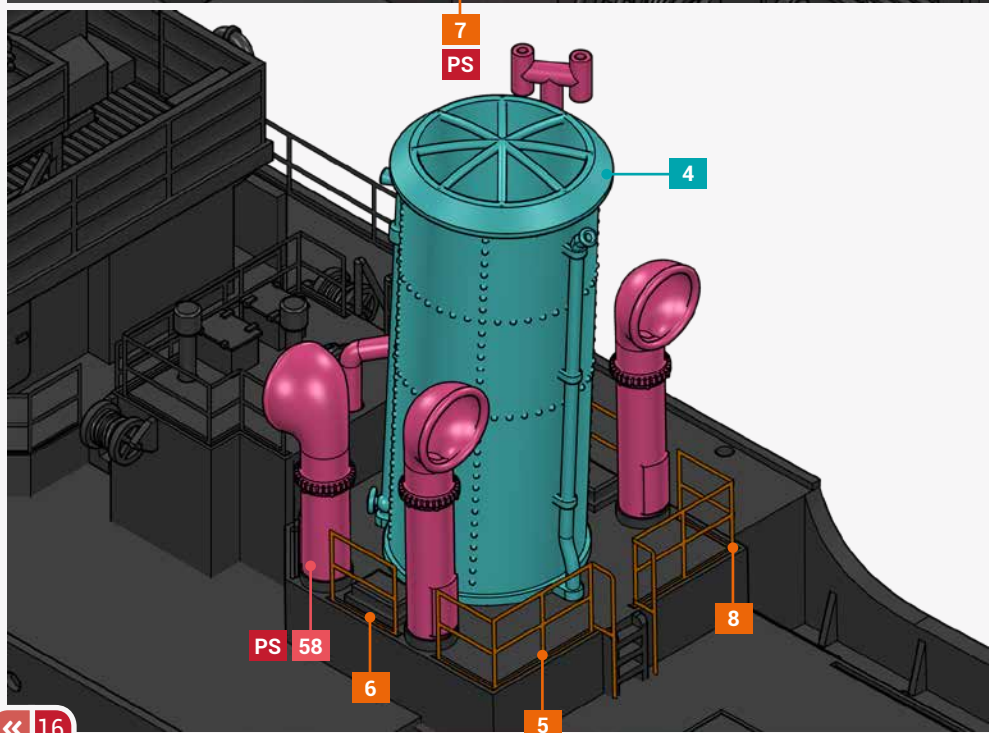
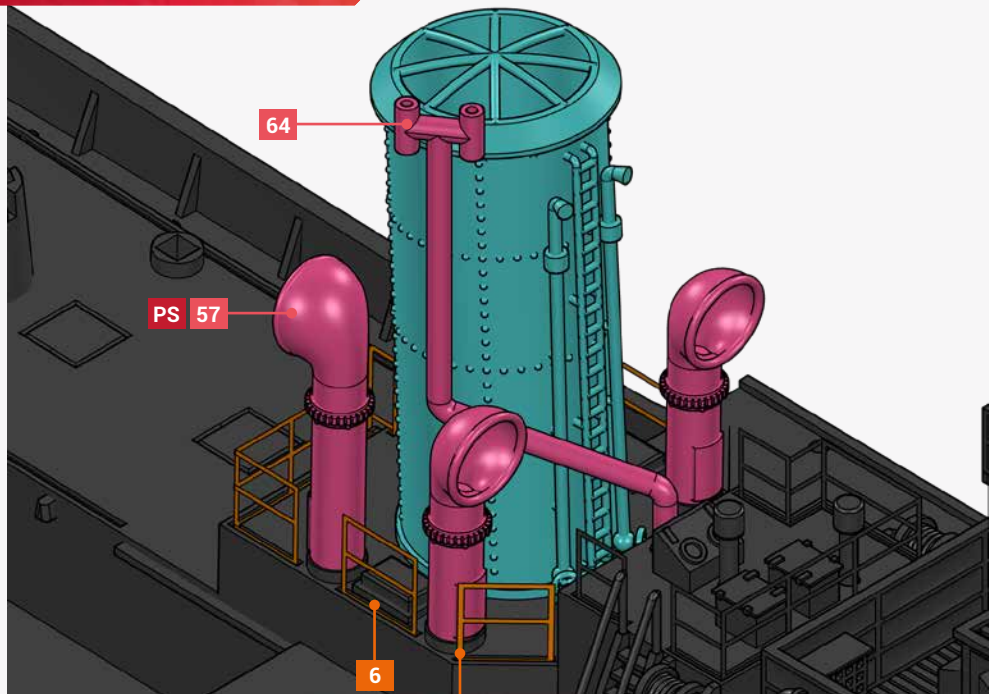

STEP 7

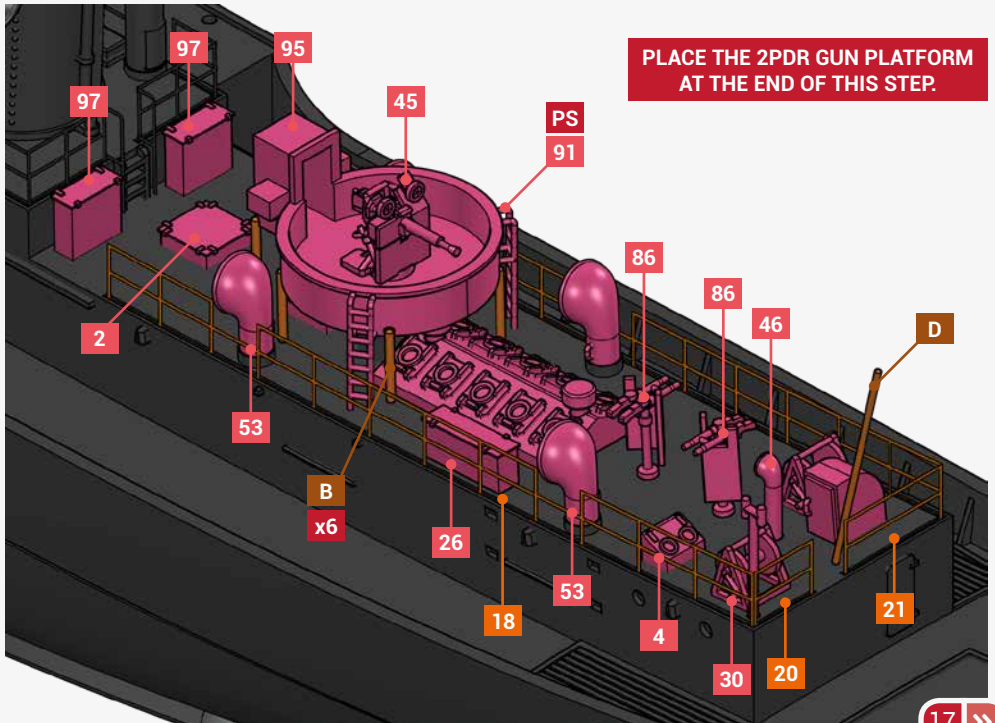
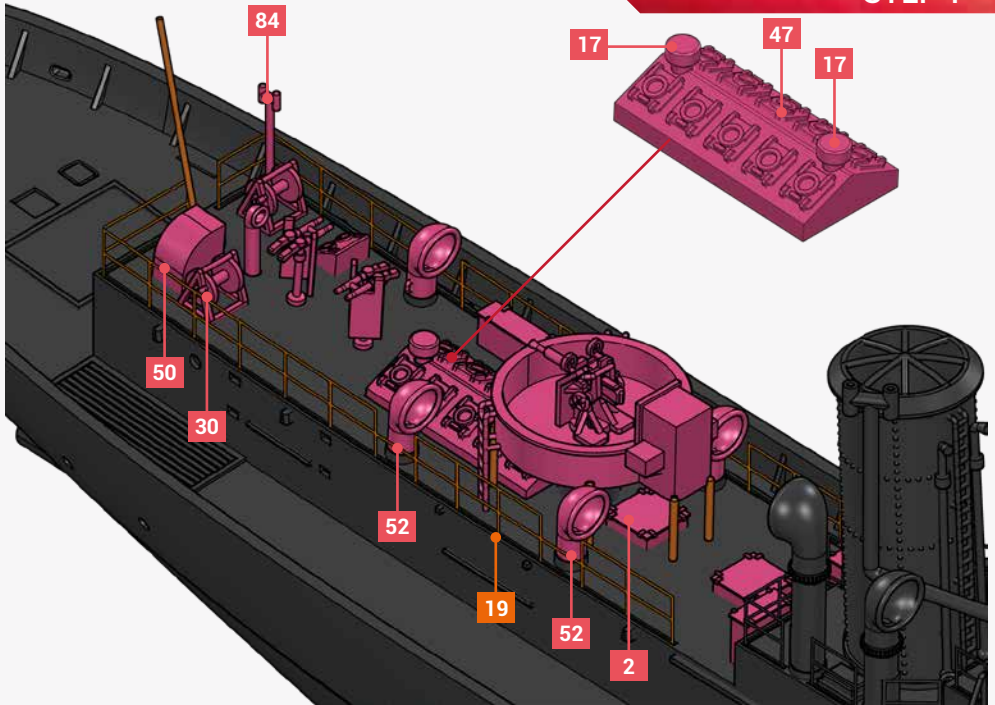

STEP 8

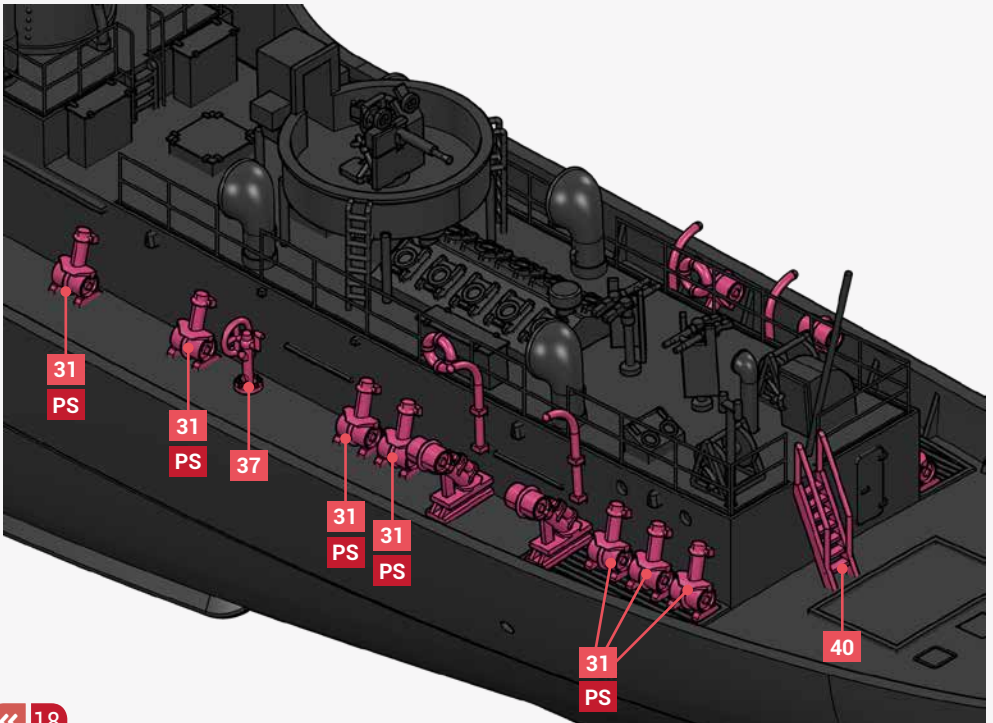
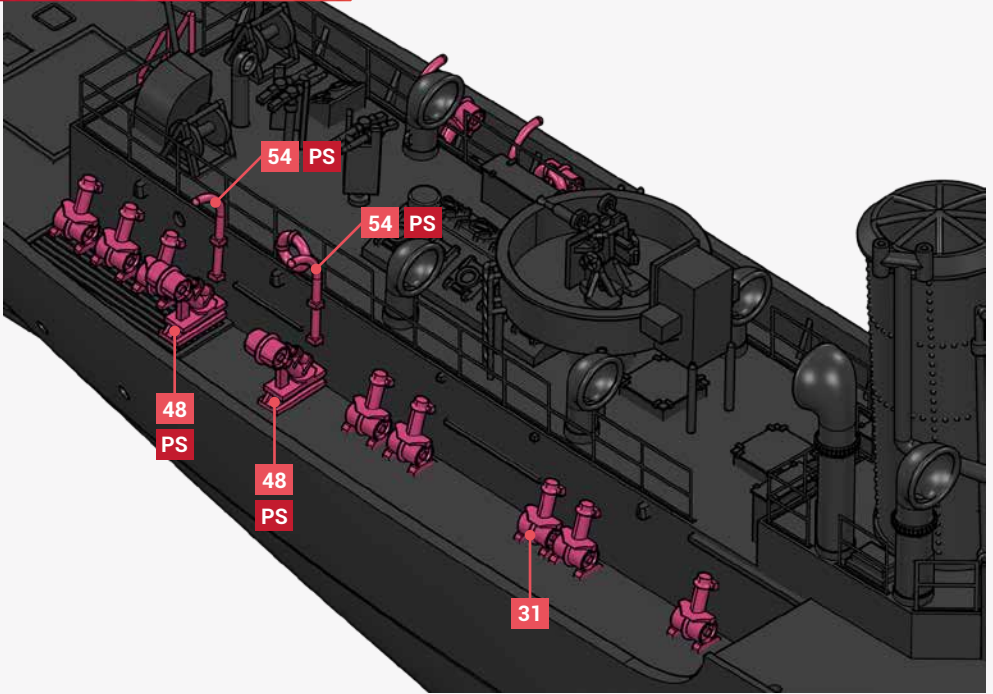

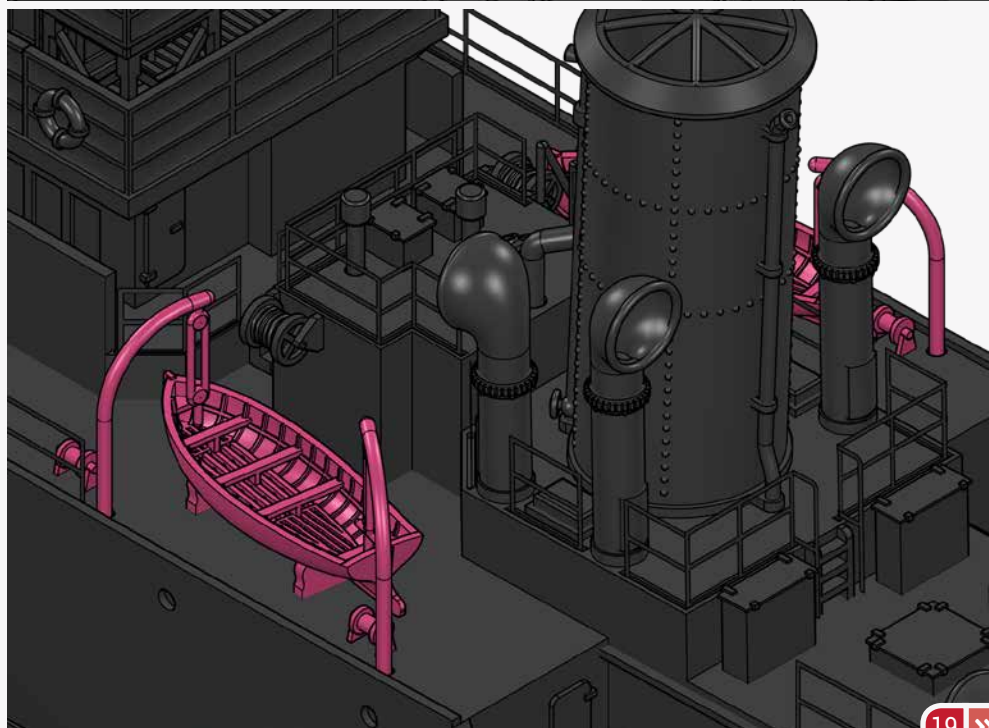
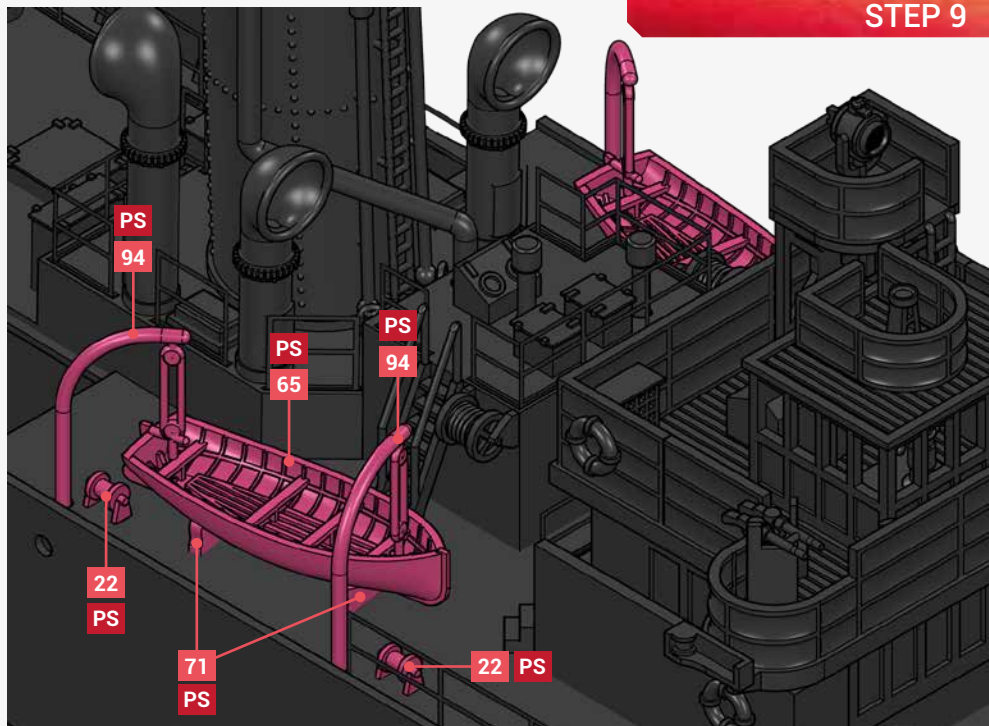

STEP 10

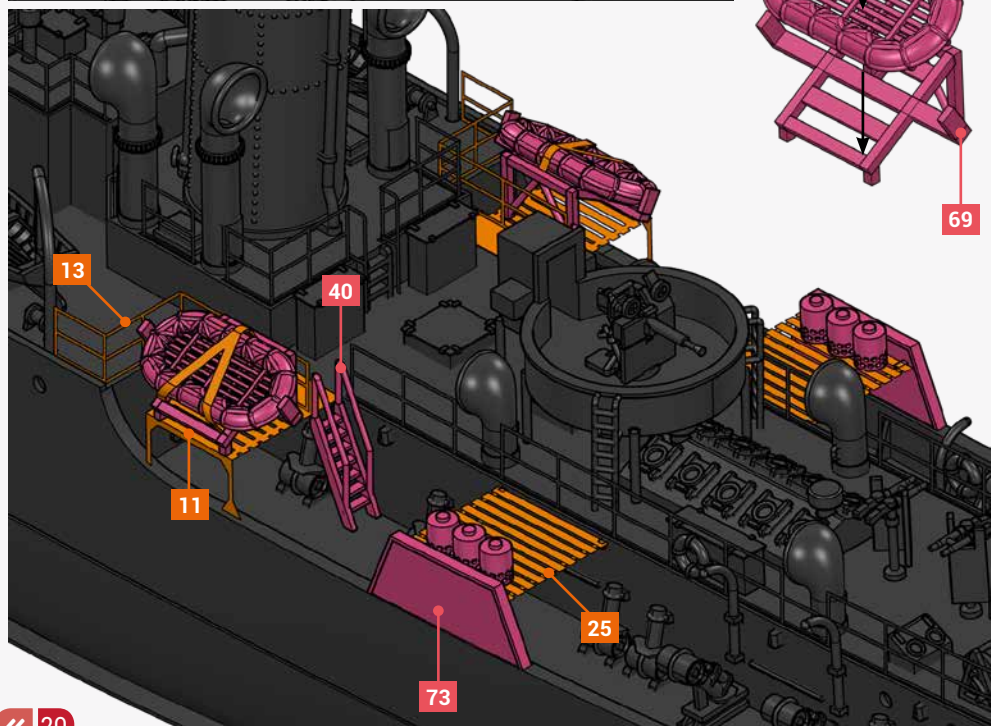
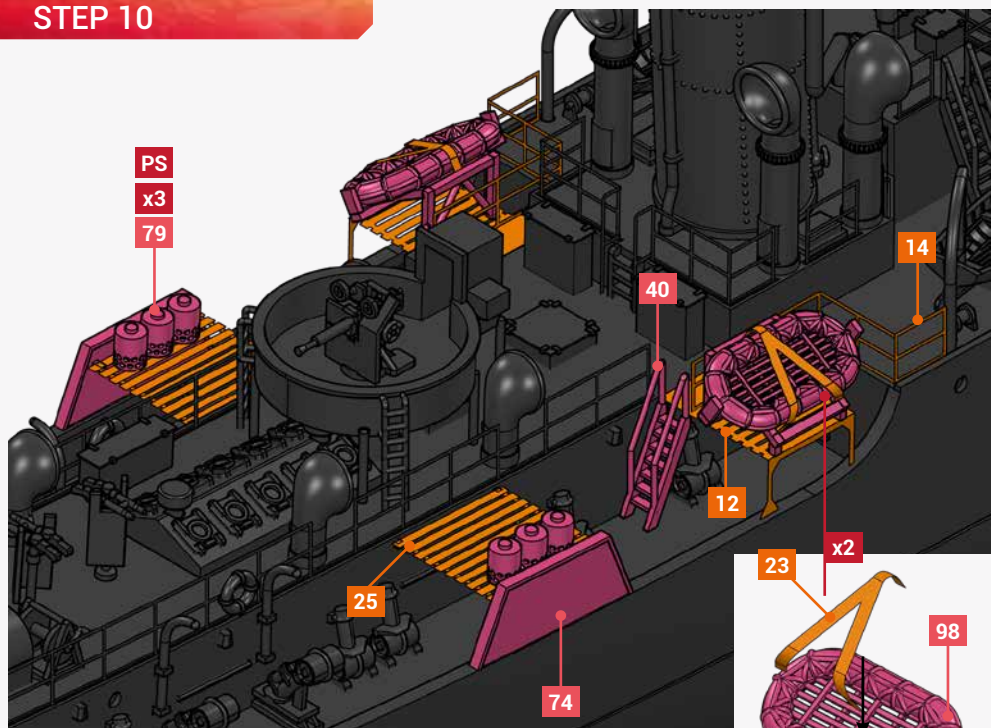

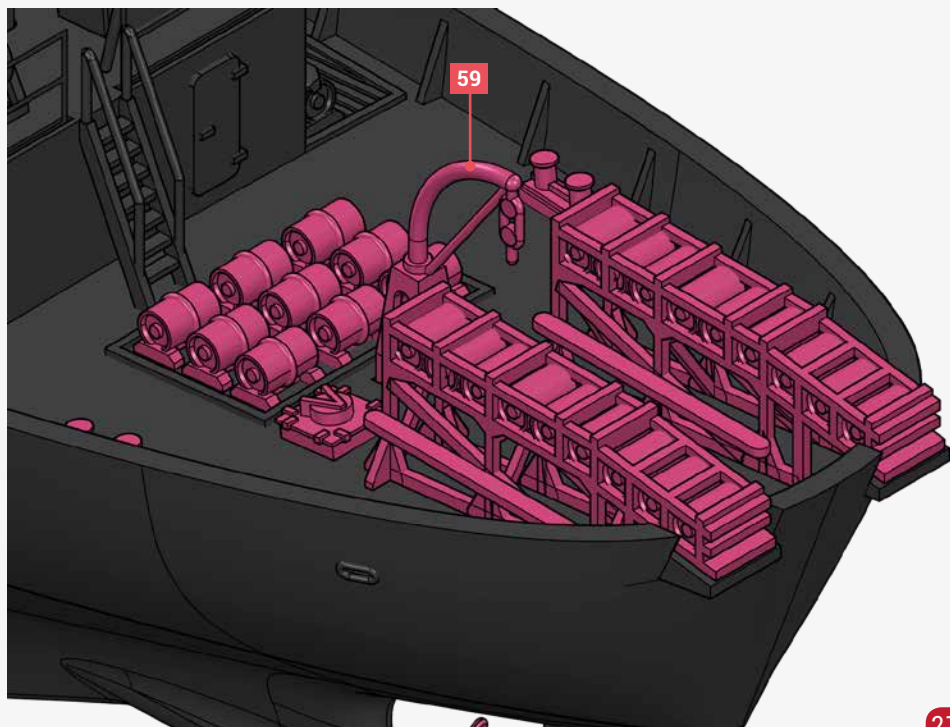
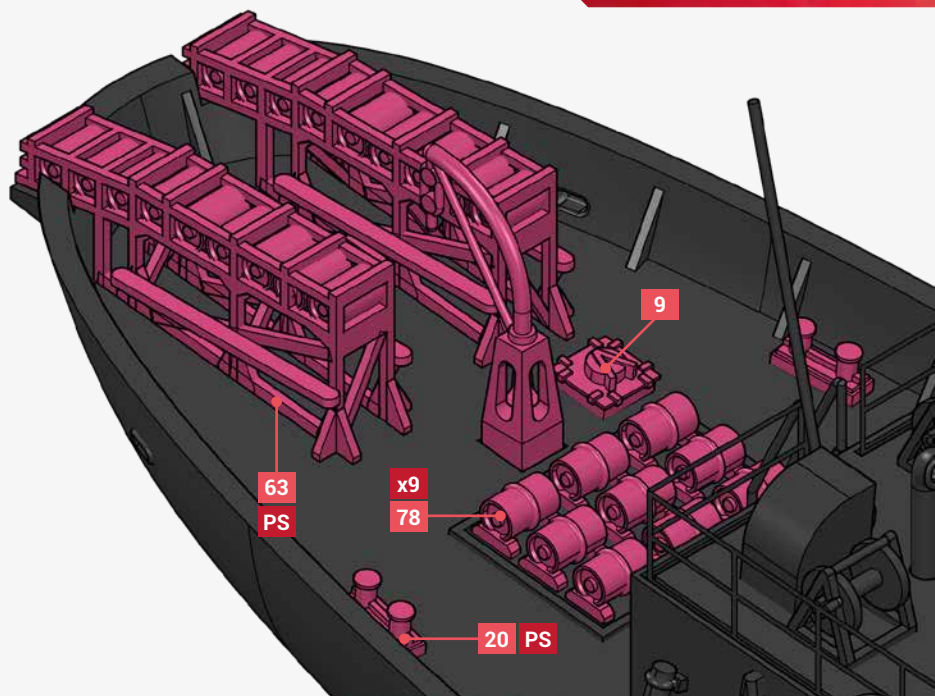



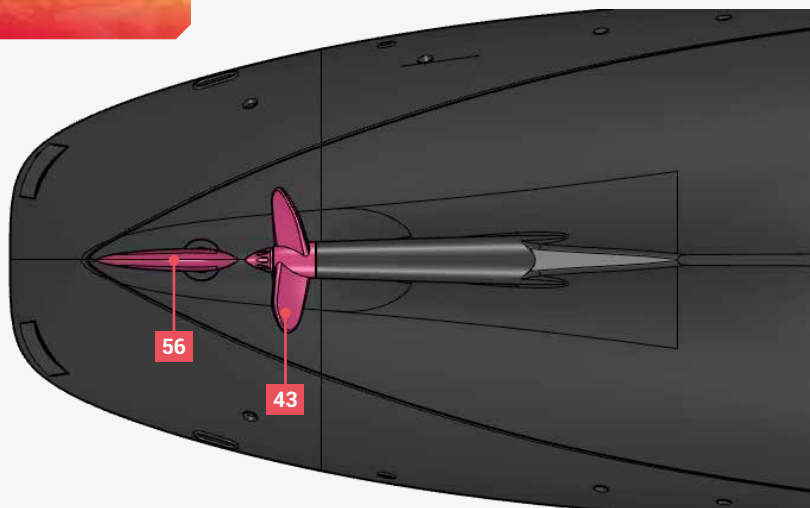

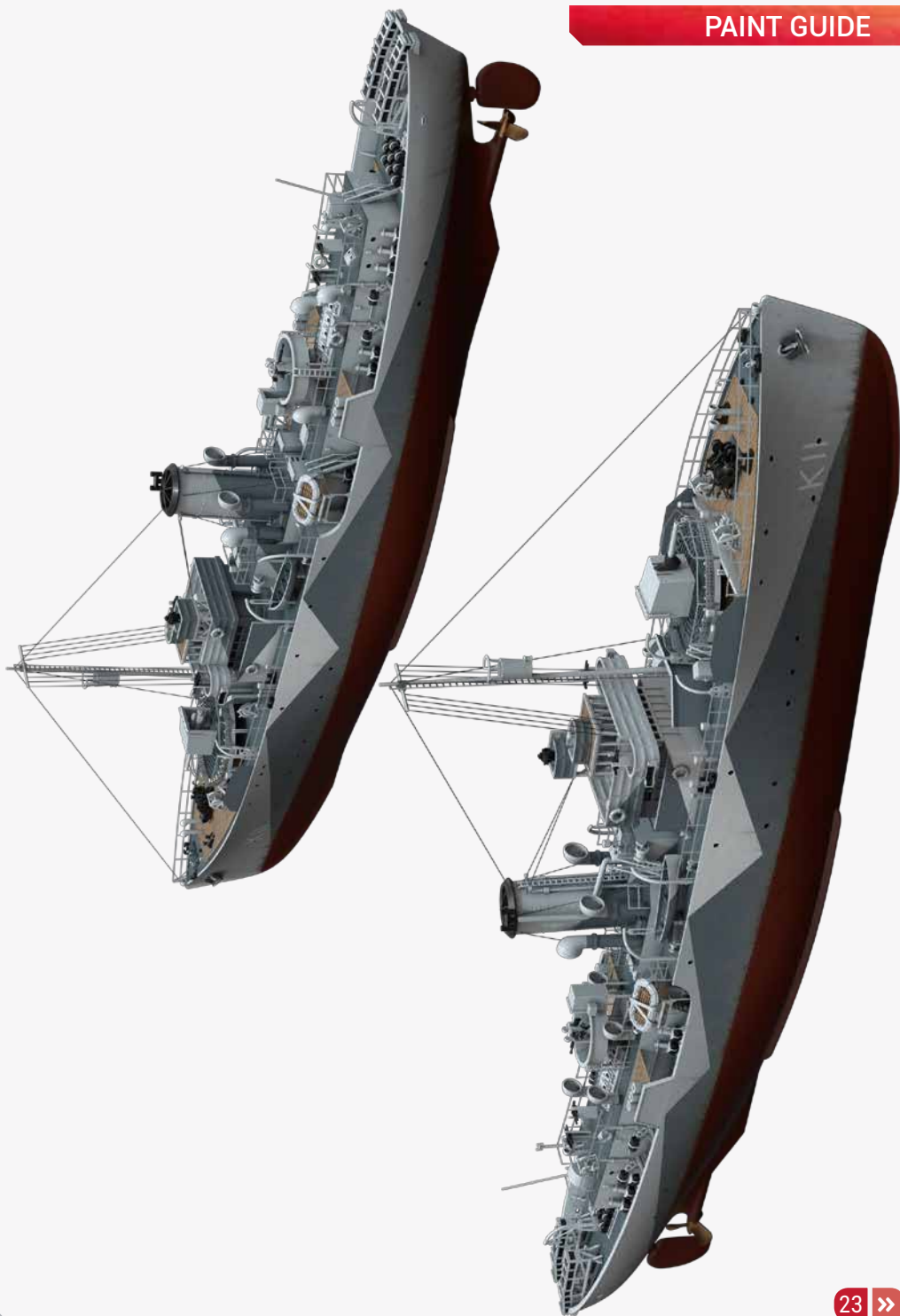
STEP 12

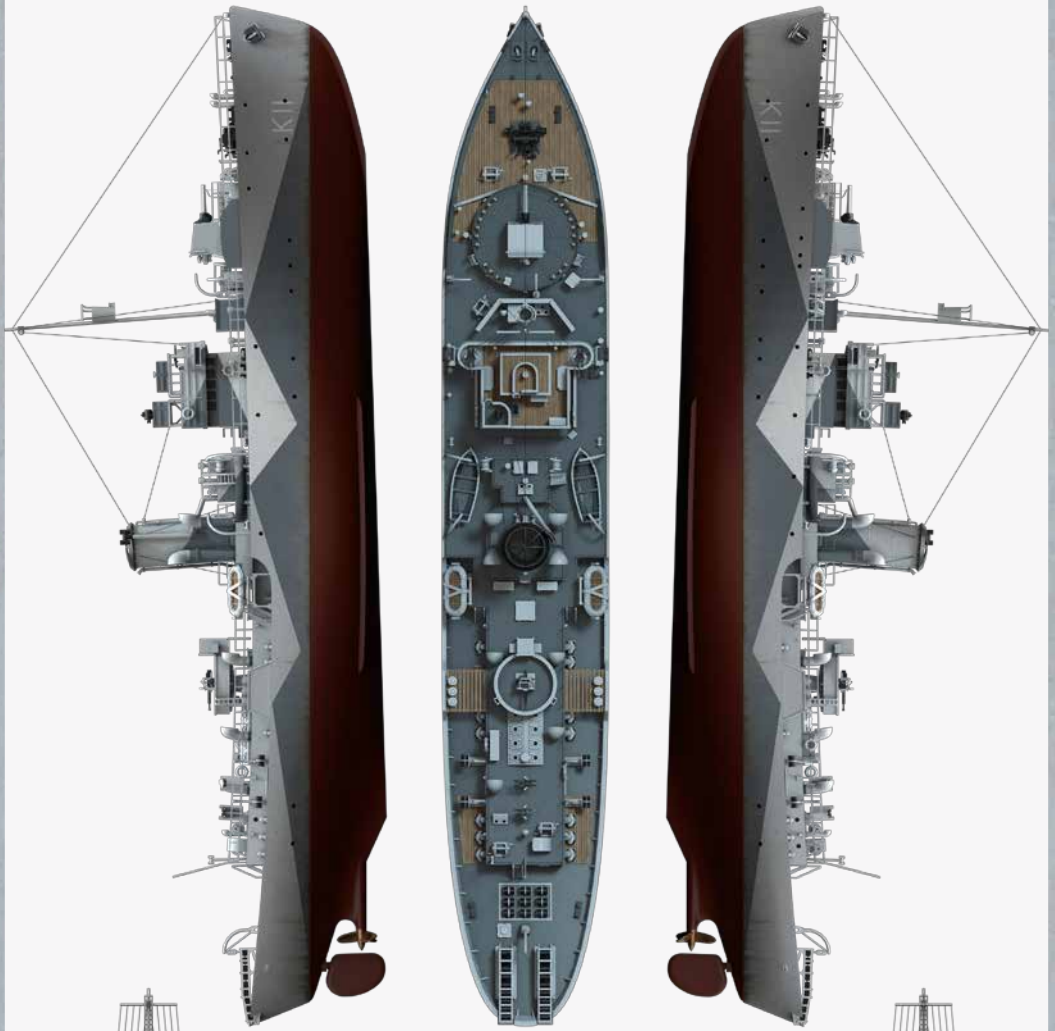





-  WHITE
-  507C
-  507B
-  ANTI FOOLING RED