



## HMCS REGINA K234 FLOWER CLASS CORVETTE

Regina was ordered as part of the Revised 1940-41 Flower class building program. This revised program radically changed the look of the Flower-class corvette.

Regina was laid down by Marine Industries Ltd. at Sorel on 22 March 1941 and launched on 14 October of that year. She was commissioned into the RCN on 22 January 1942 at Halifax, Nova Scotia. Regina had only one significant refit during her career, beginning at Sydney, Nova Scotia in June 1943 and completed at Pictou, Nova Scotia in mid-December 1943. After completion, she needed further repairs at Halifax and Shelburne.

After commissioning and workups, Regina was assigned to the Western Local Escort Force (WLEF). On 3 July 1942 Regina rescued 25 survivors of the American merchant SS Alexander Macomb which was sunk east of Cape Cod. In September she was assigned to Operation Torch, the Allied invasion of North Africa.

On 8 February 1943, Regina attacked and sank the Italian submarine Avorio off Philippeville, Algeria. She returned to Canada in late March 1943 and briefly rejoined WLEF before departing for a refit in June. At the end of March, Regina was assigned to Western Approaches Command for invasion duties associated with Operation Neptune, the naval component of the invasion of Normandy. After the invasion she was used as a coastal convoy escort in the English Channel.

On 8 August 1944, Regina was torpedoed and sunk by U-667 8 nautical miles (15 km) north of Trevoze Head on the coast of Cornwall while rescuing survivors of the American merchant Liberty ship Ezra Weston. The warship sank in 28 seconds. Thirty of the ship's crew were killed. The wrecks of Regina and Ezra Weston rest in 60 metres (200 ft) of water.

XX	RESIN PARTS
XX	3D PARTS
XX	PHOTOETCH PARTS
XX	BRASS PARTS
XX	DECALS PARTS

!	ASSEMBLY WARNING
PS	PORT & STARBOARD
P	PORT SIDE
S	STARBOARD SIDE
X	INFORMATIONS

SOME PHOTOETCH AND 3D PARTS ARE PROVIDED IN EXTRA NUMBERS.

IMPORTANT ! PLEASE FULLY READ THE INSTRUCTIONS BEFORE STARTING THE BUILD !

## DECALS

KI8I KI8I KI8I ♣ KII  
 KI66 KI66 KI66 KII  
 KI66 KI66 KI66 KII  
 K0123456789  
 K0123456789  
 K0123456789  
 K0123456789  
 K0123456789  
 K0123456789  
 K0123456789  
 K0123456789

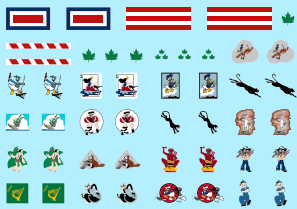

SOME 3D AND BRASS PARTS ARE PROVIDED TO CONSTRUCT AN ALTERNATE VERSION OF THE SHIPS.

## PHOTOETCH

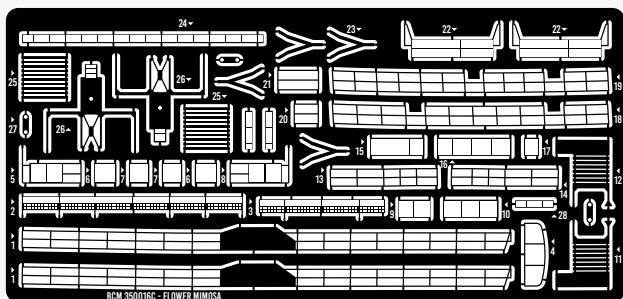

## BRASS

A	x1	Ø=0.83MM L=42MM
B	x6	Ø=0.4MM L=4MM
C	x1	Ø=0.4MM L=10MM
D	x1	Ø=0.4MM L=13MM

## PARTS

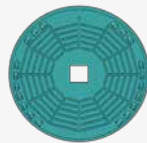
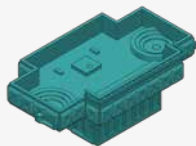
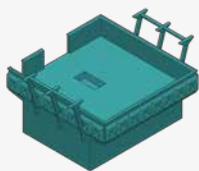
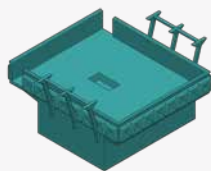
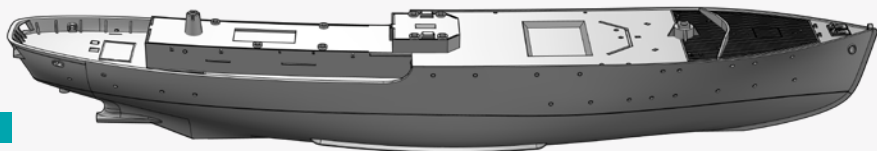

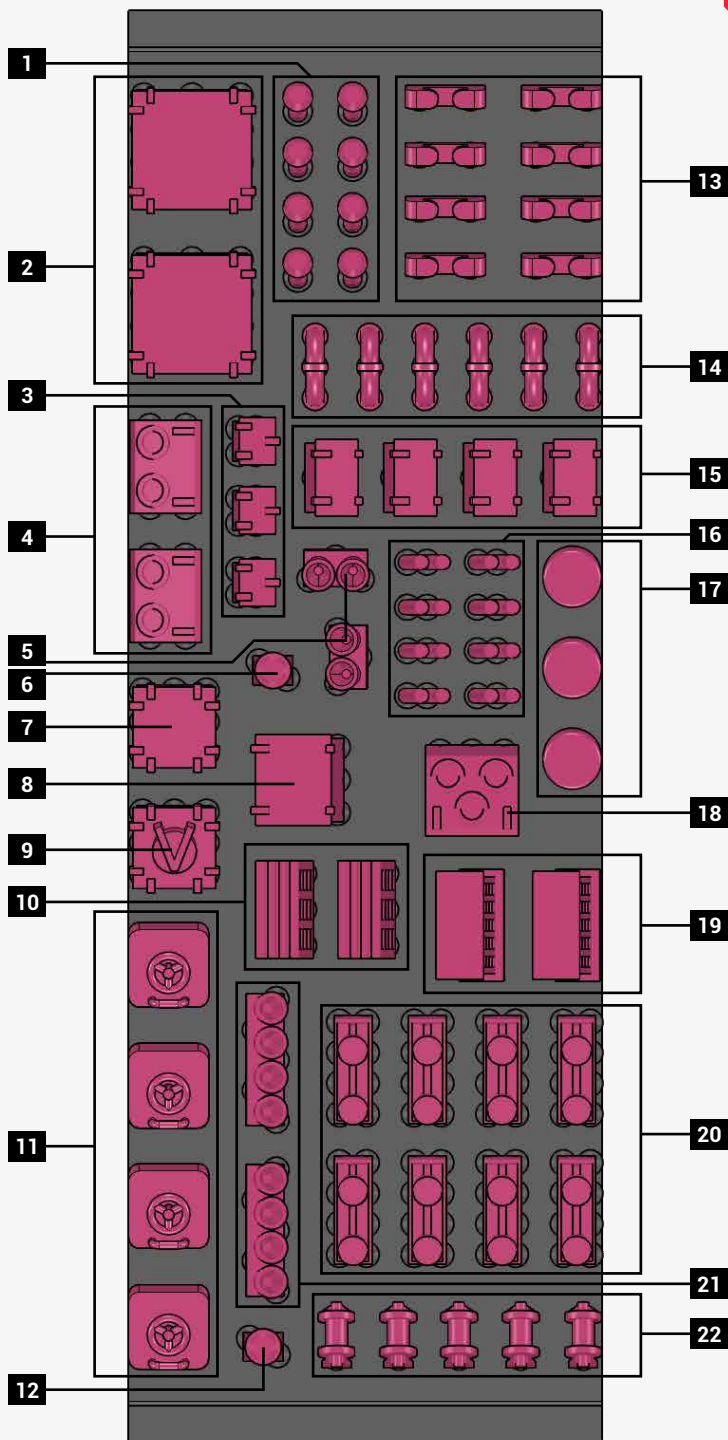

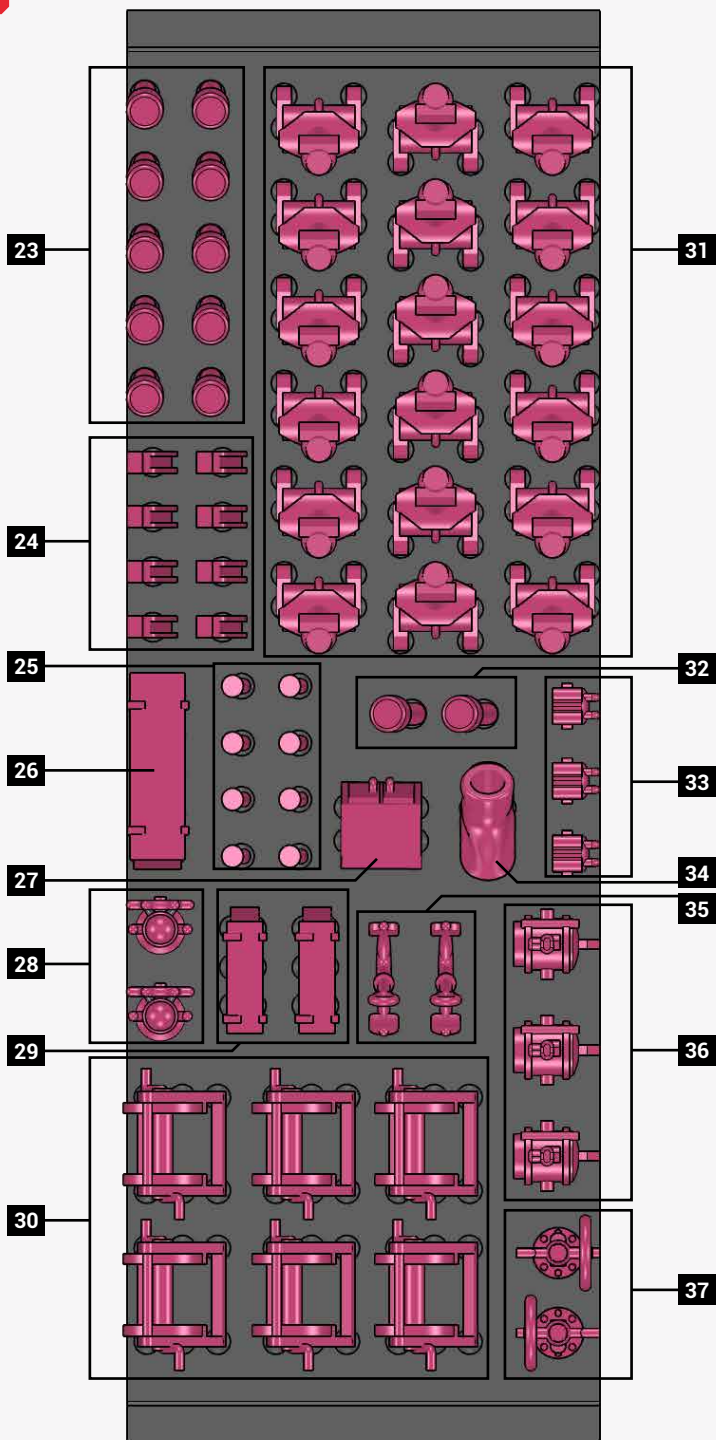



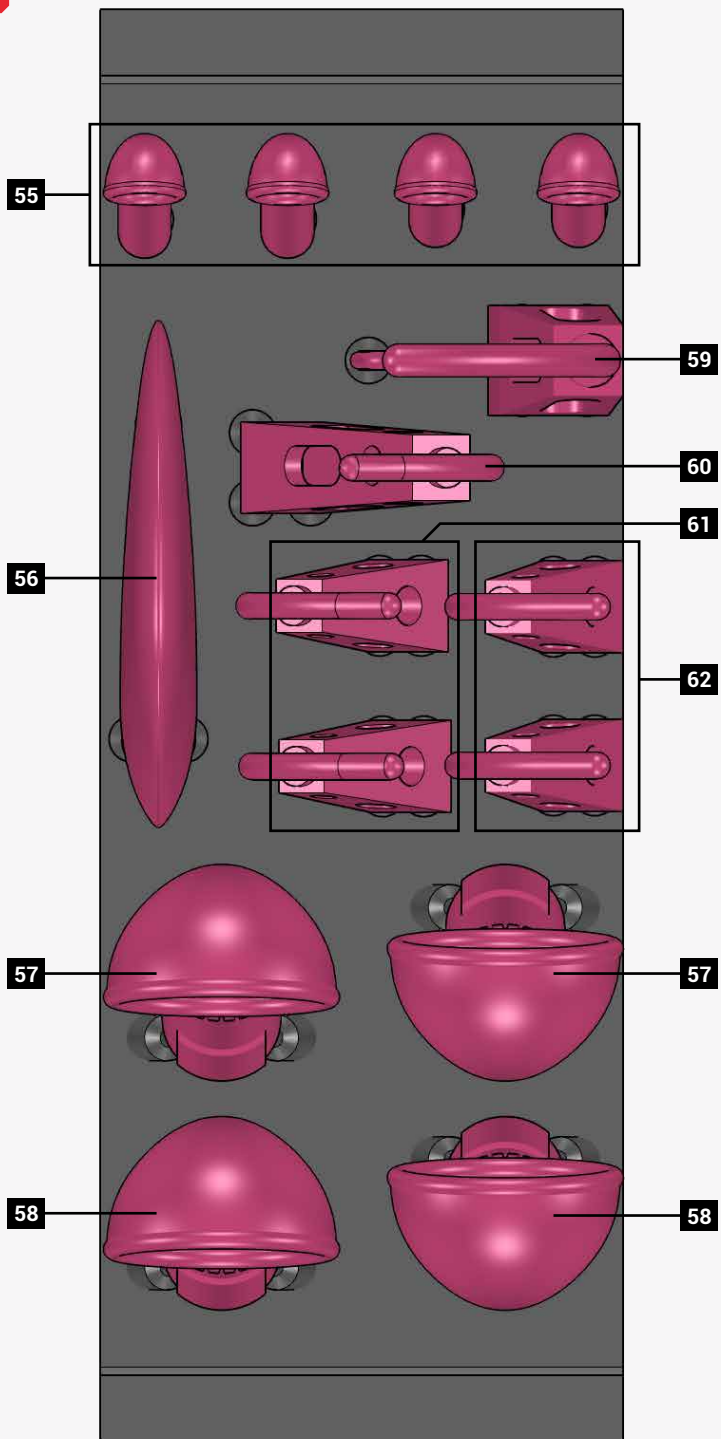

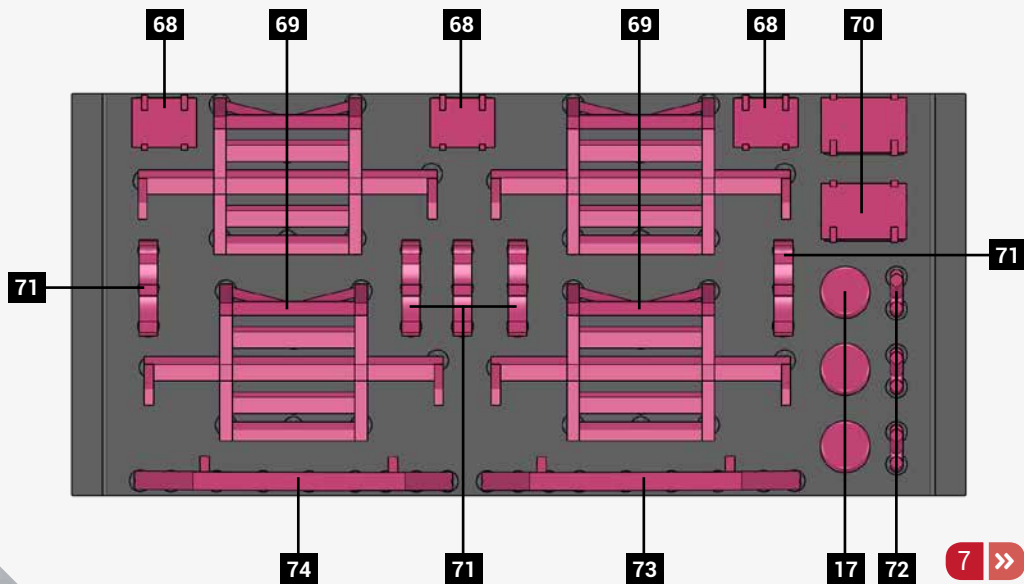
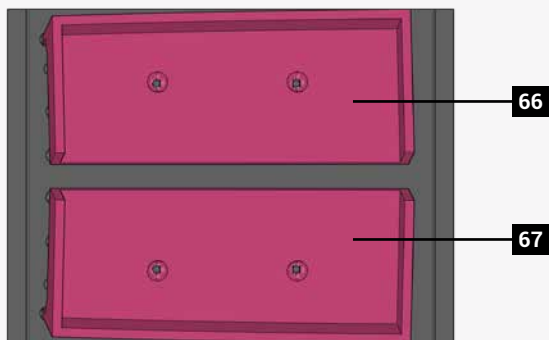
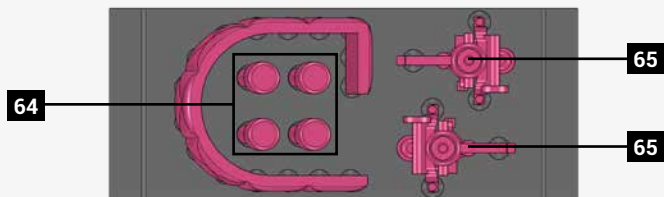
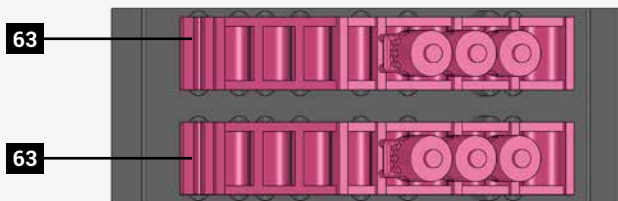

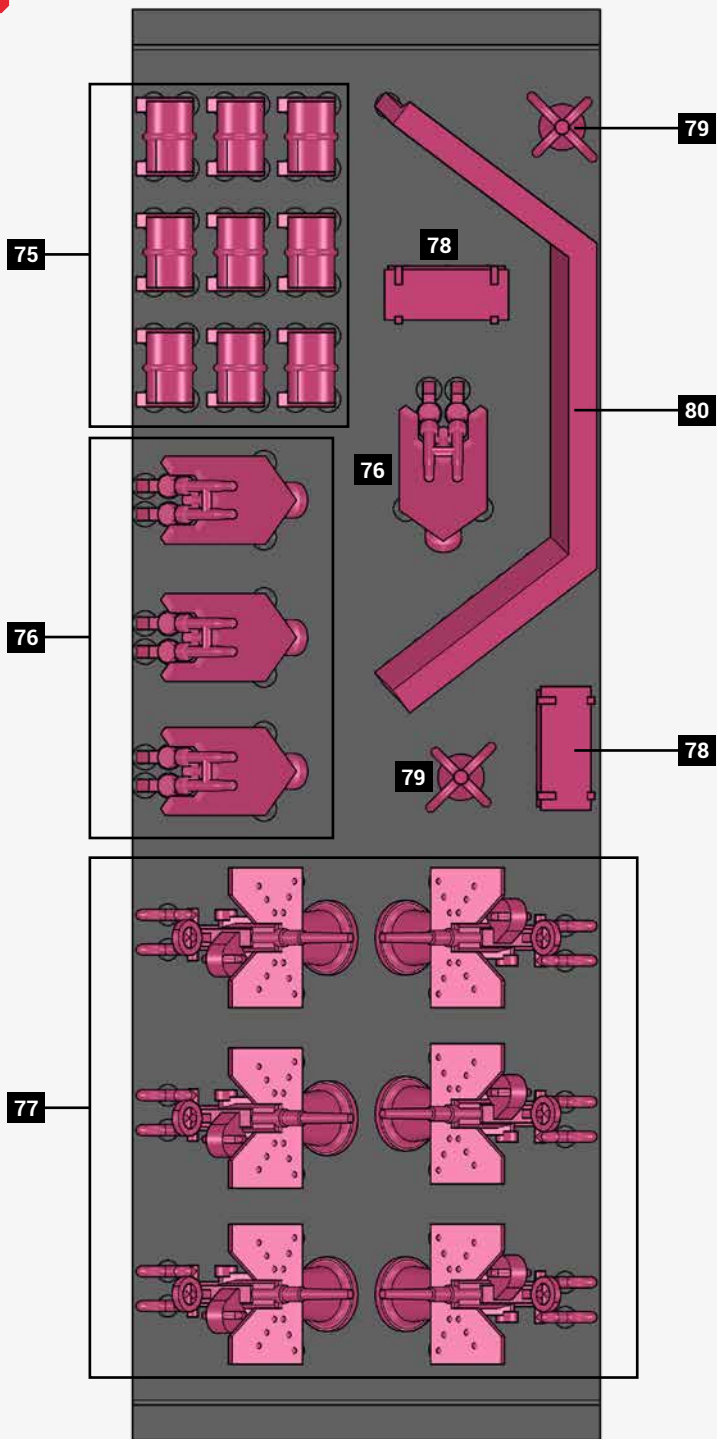

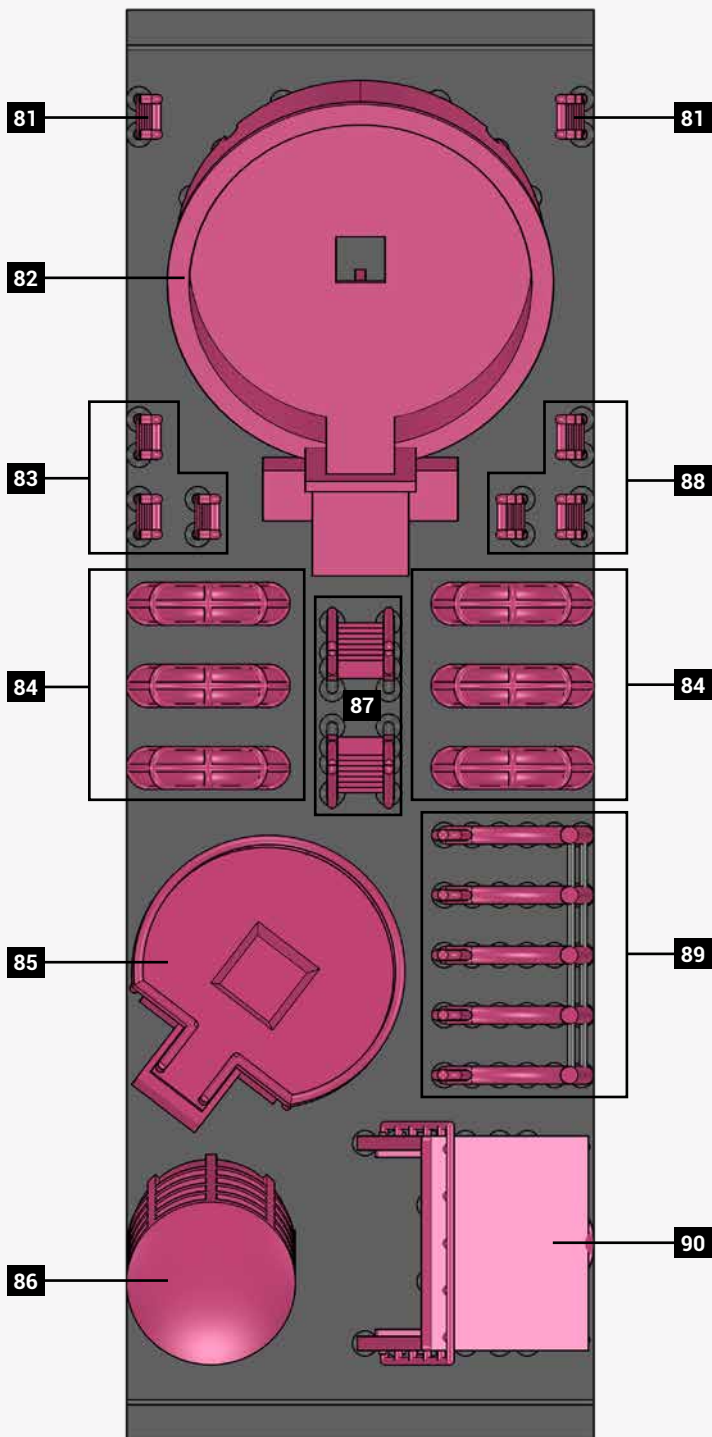

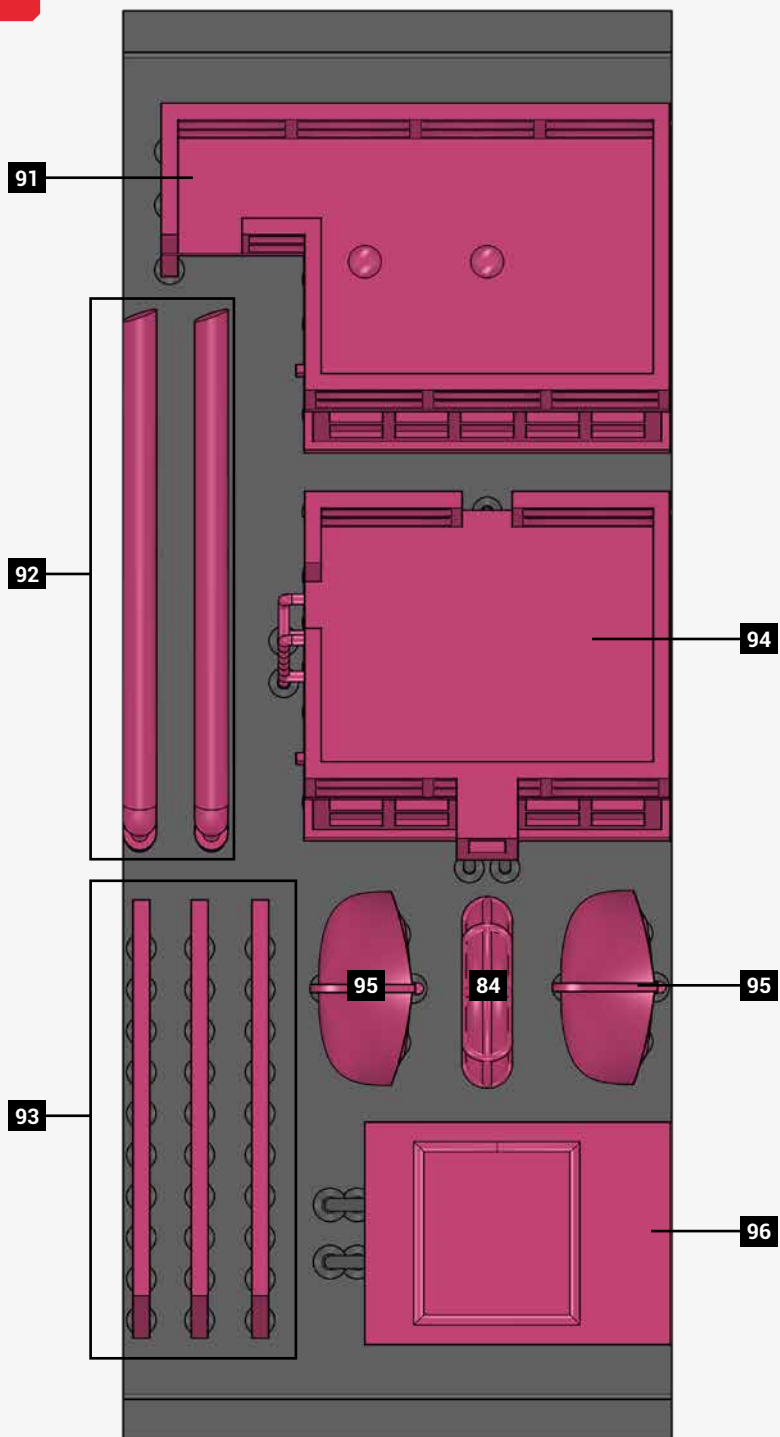

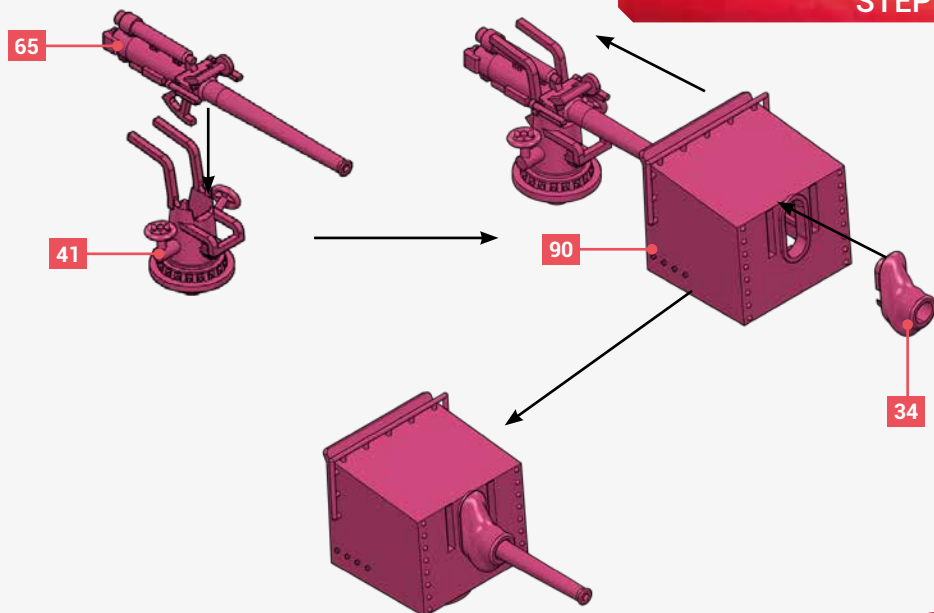
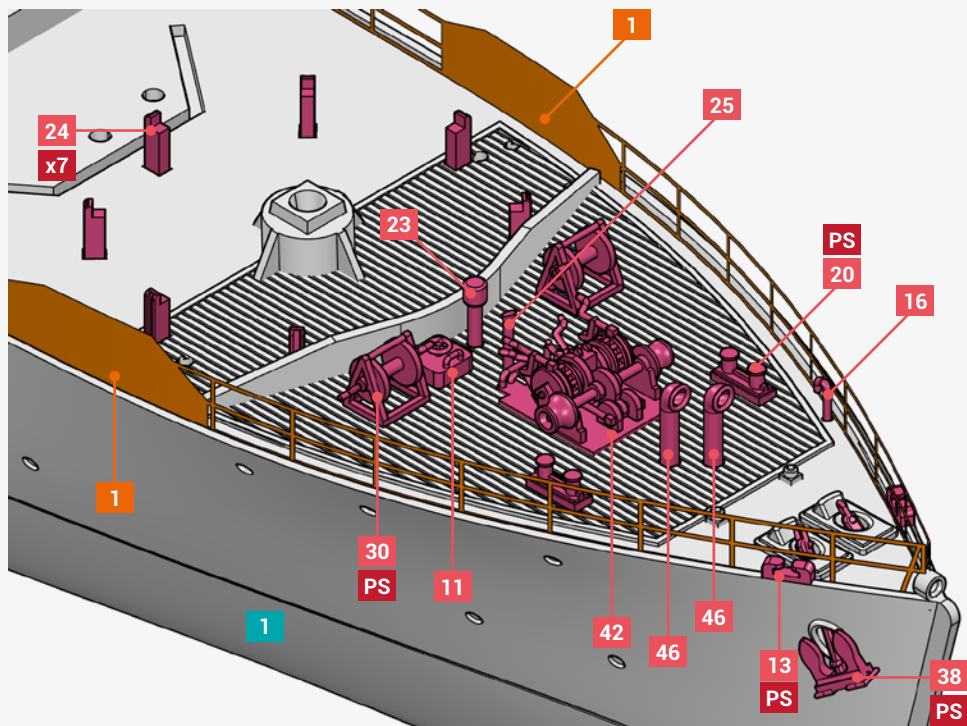

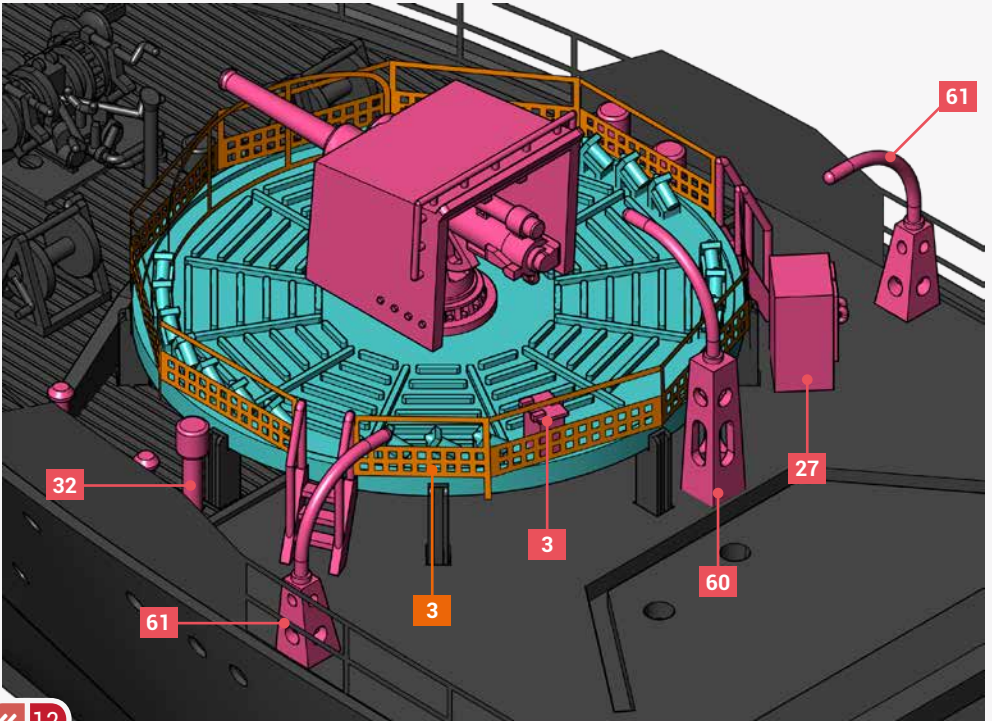
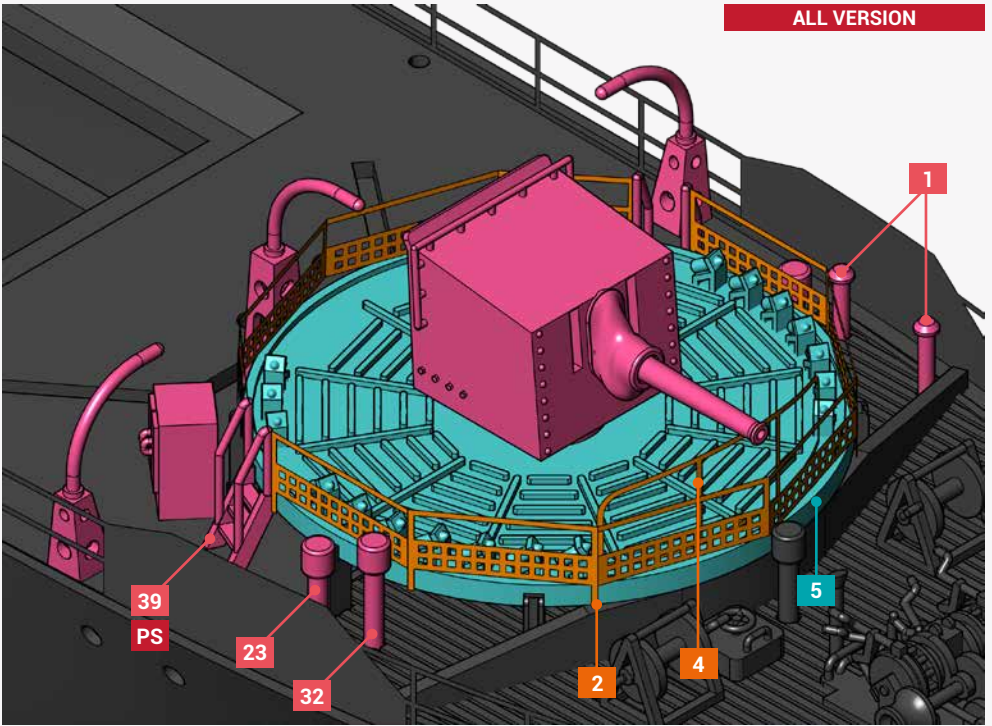

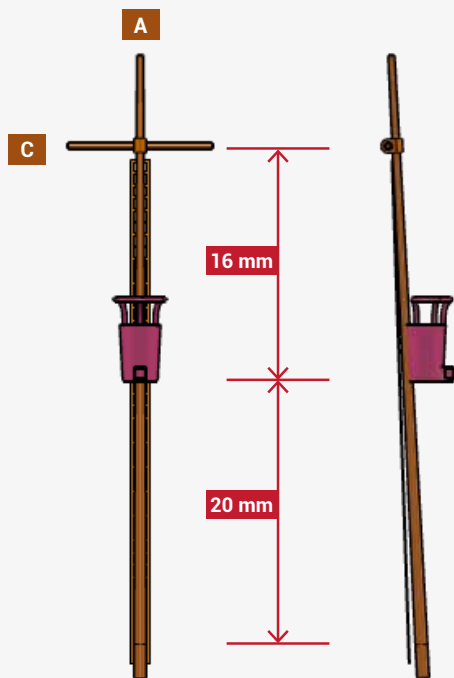
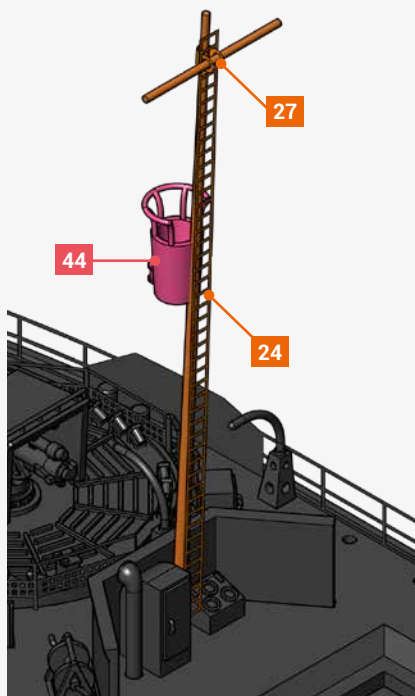
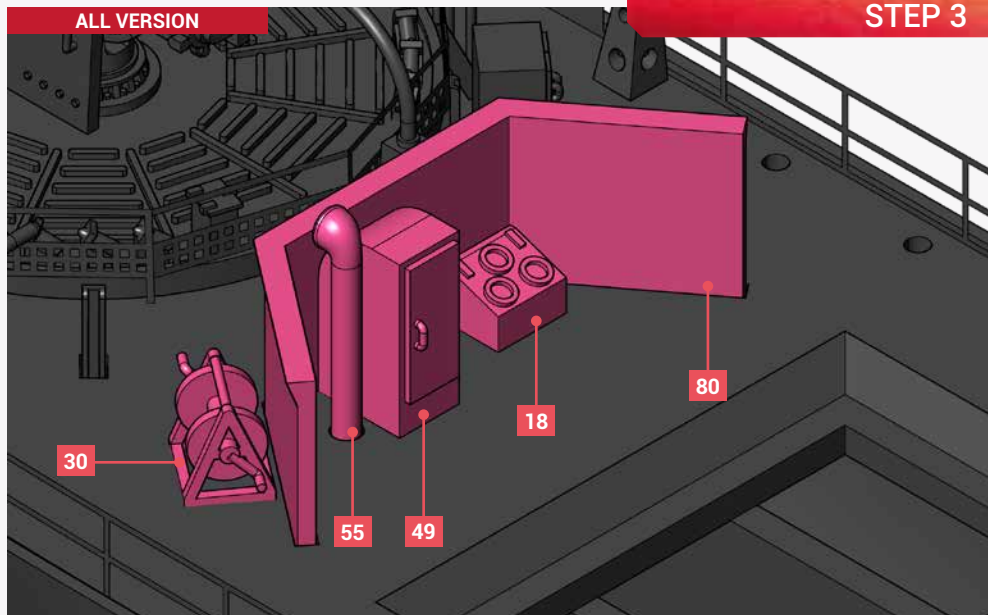

# STEP 5

EARLY VERSION

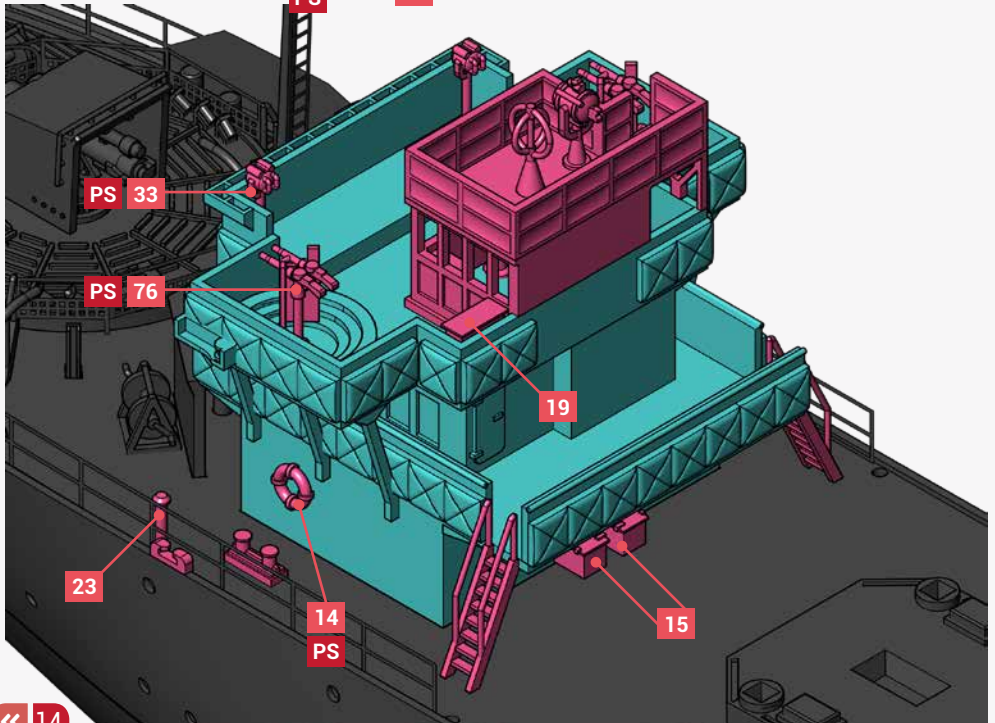
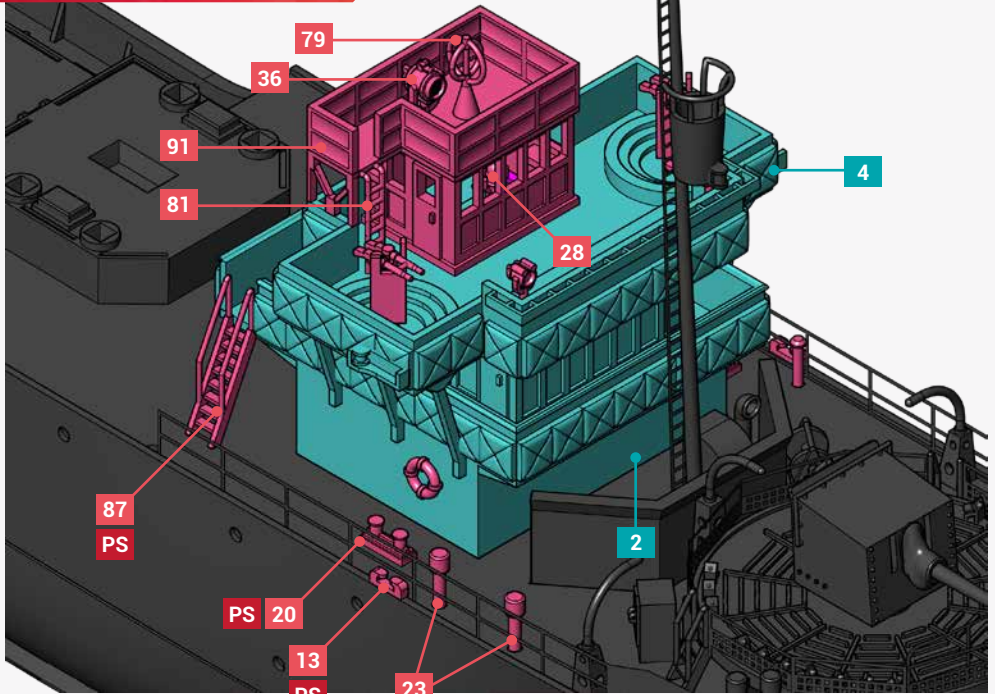

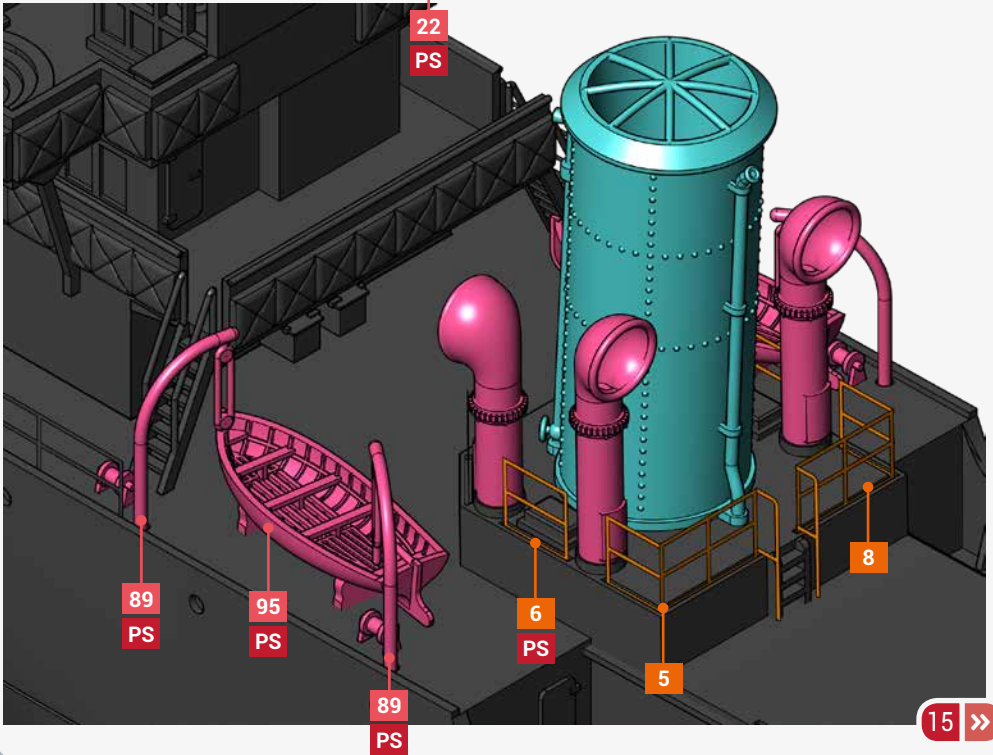
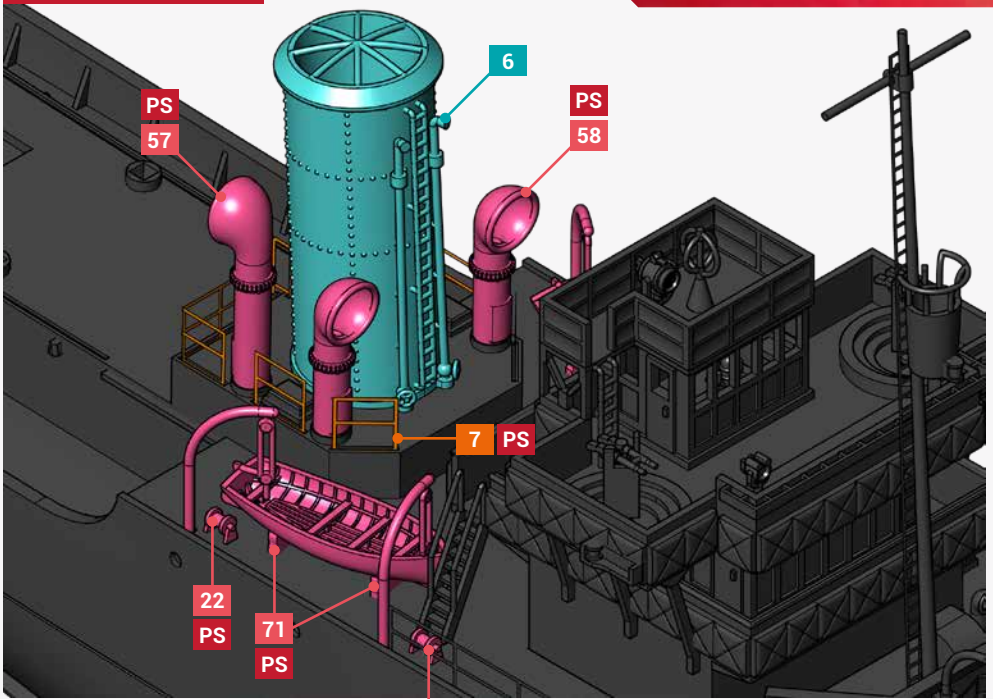

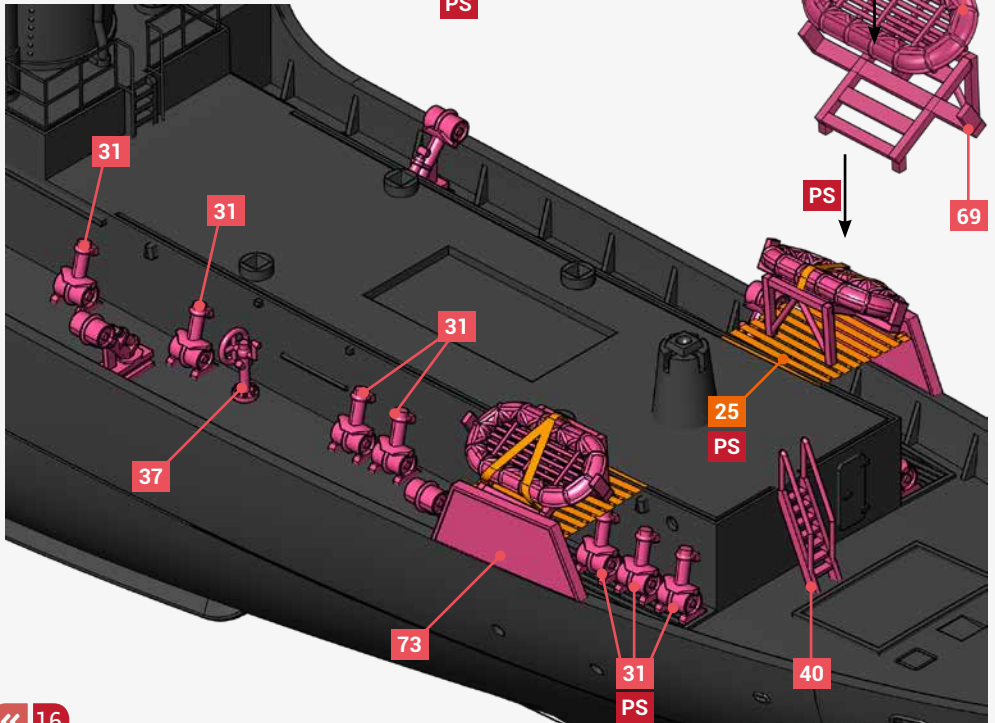
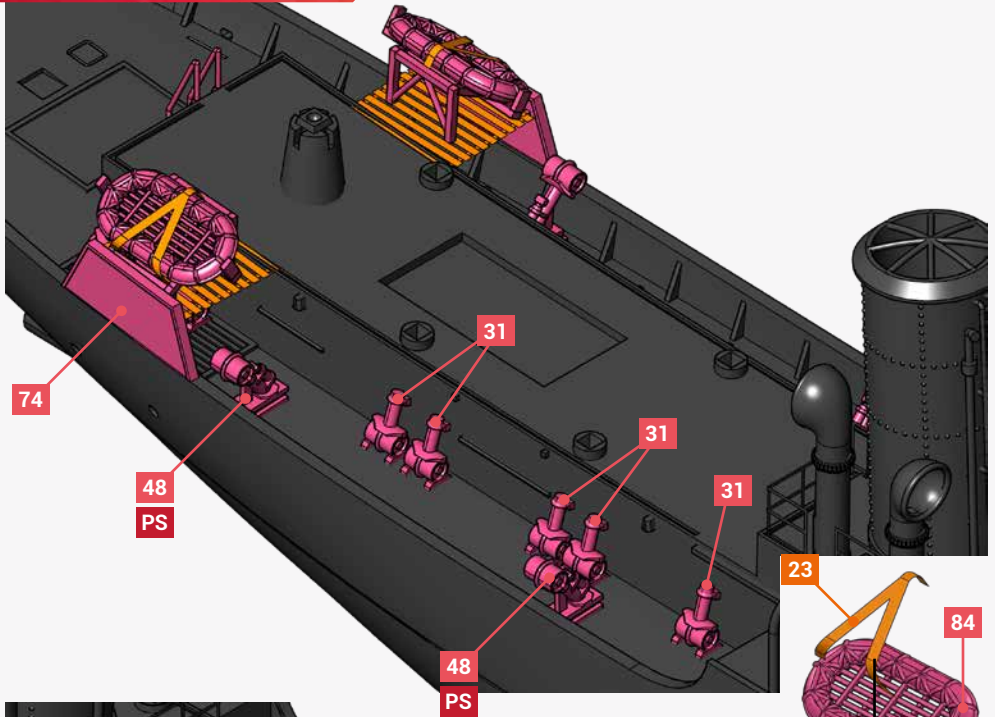

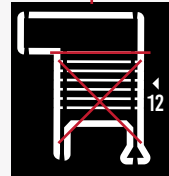
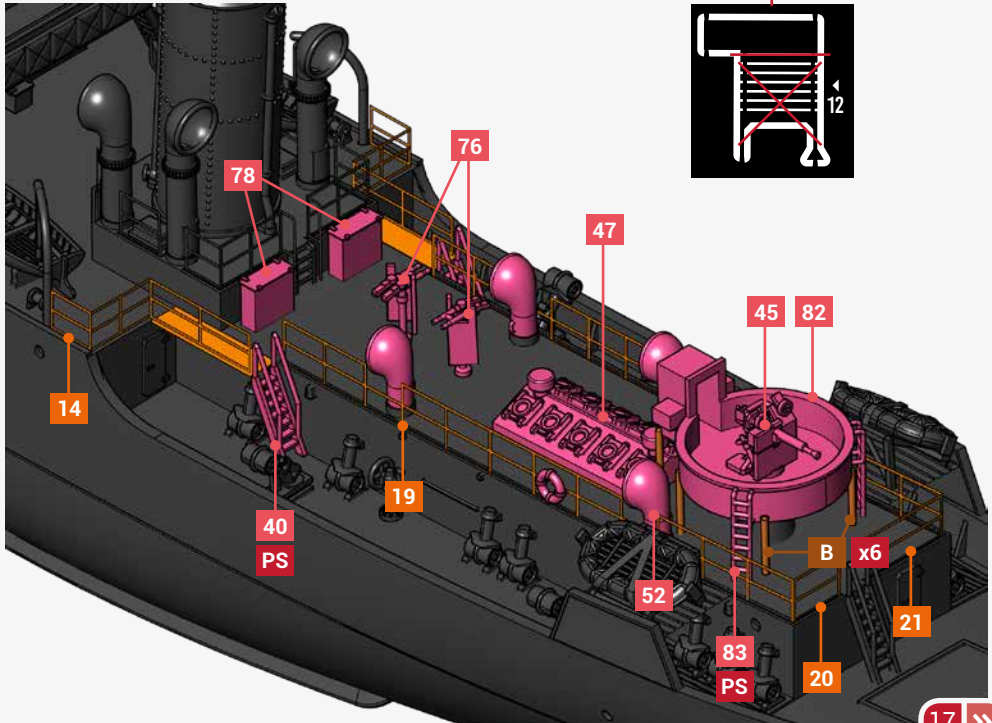
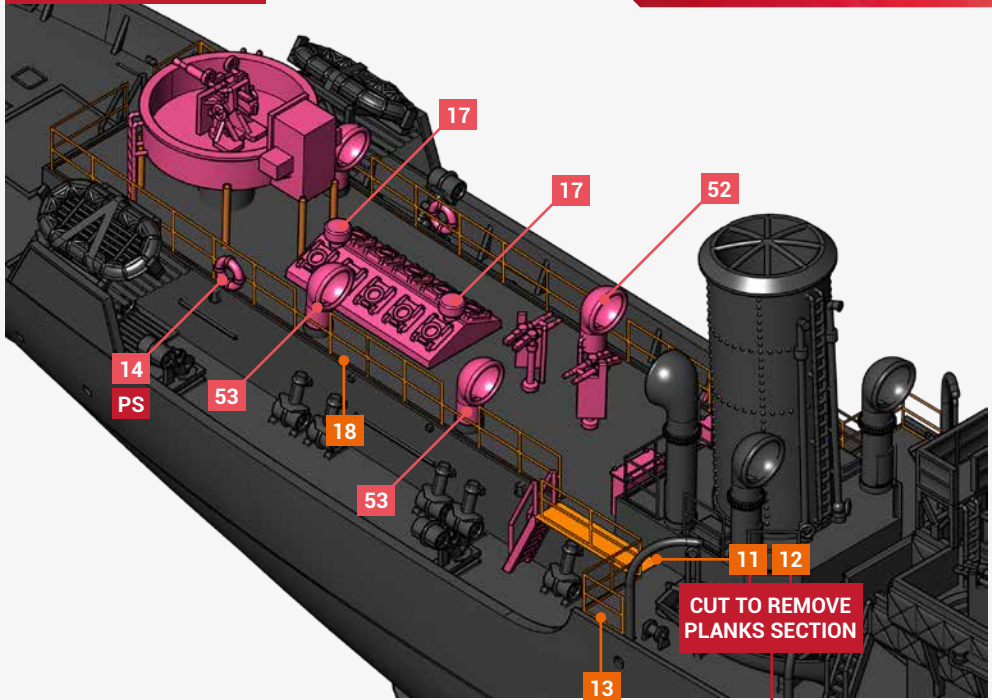

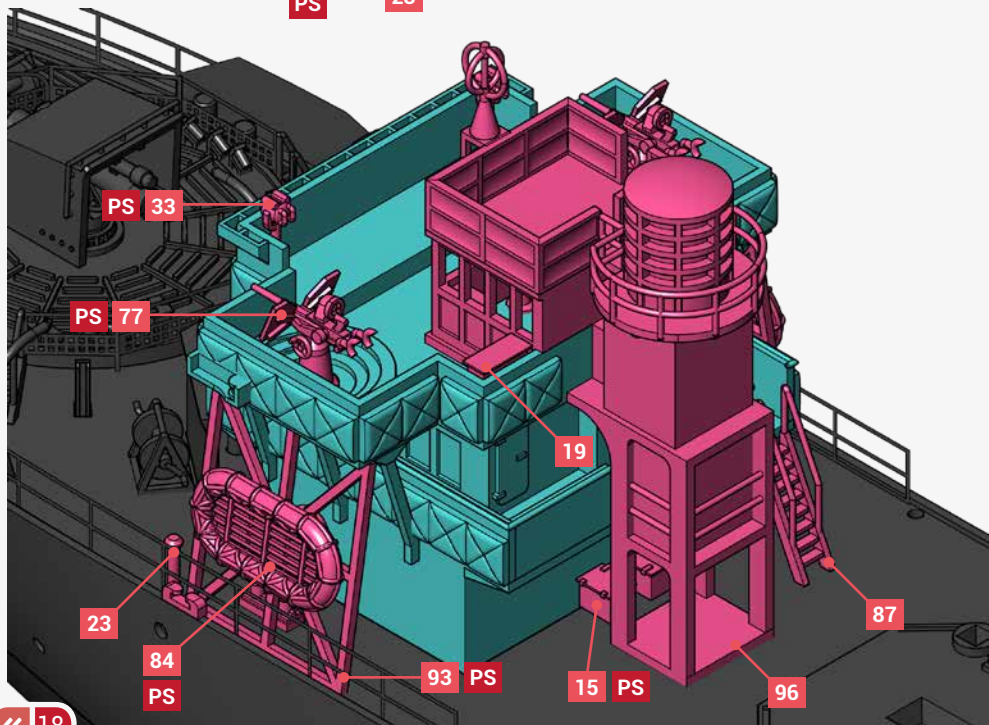
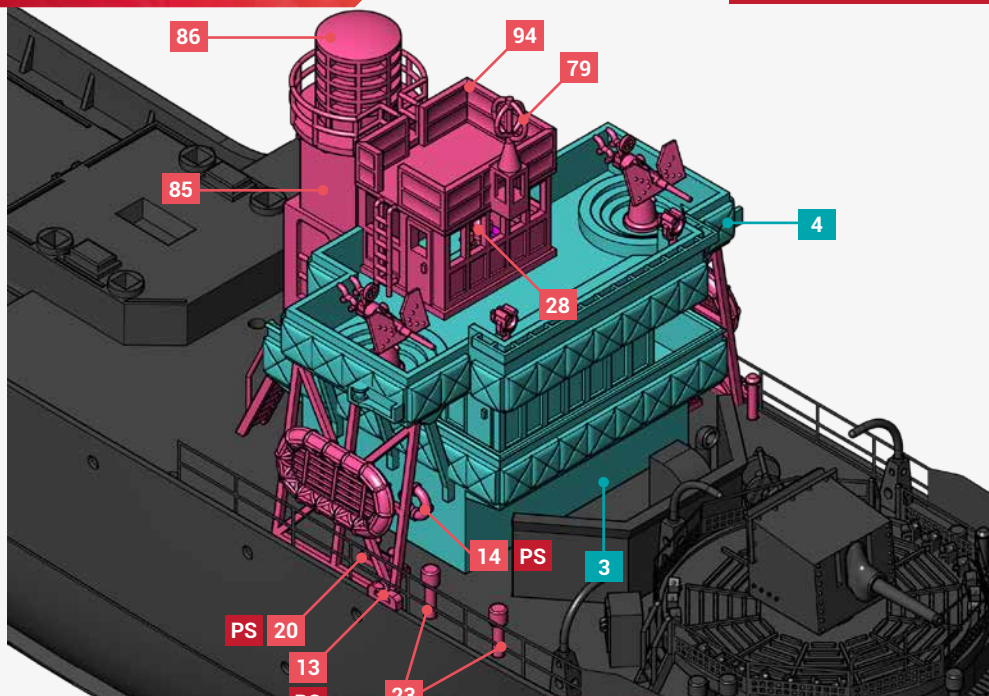

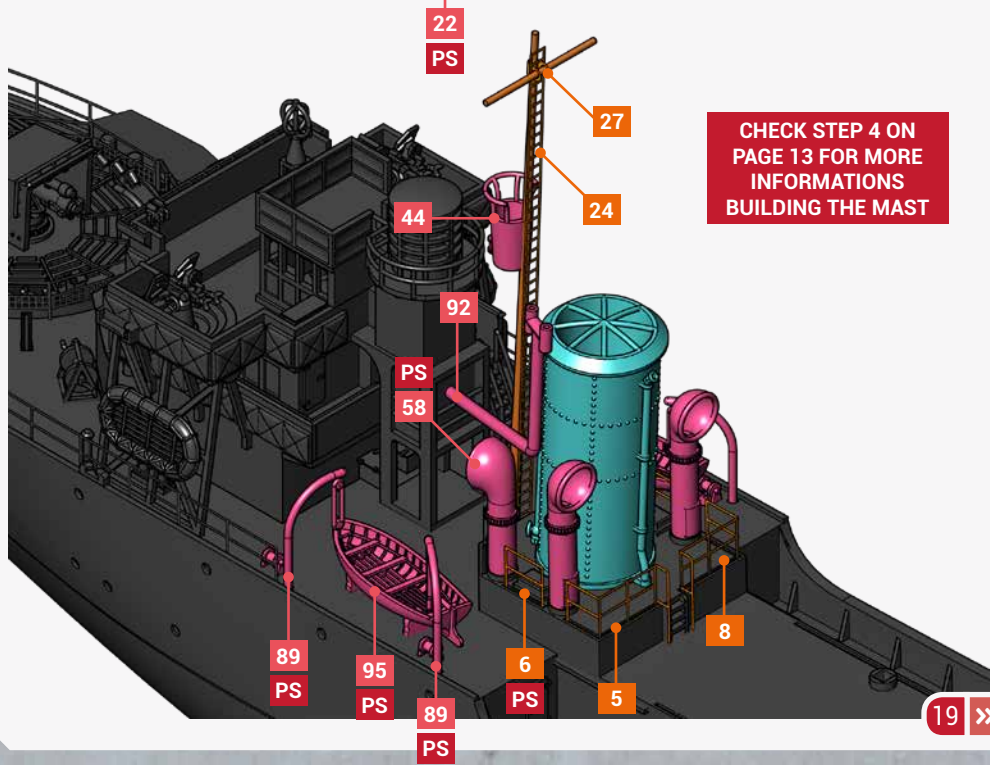
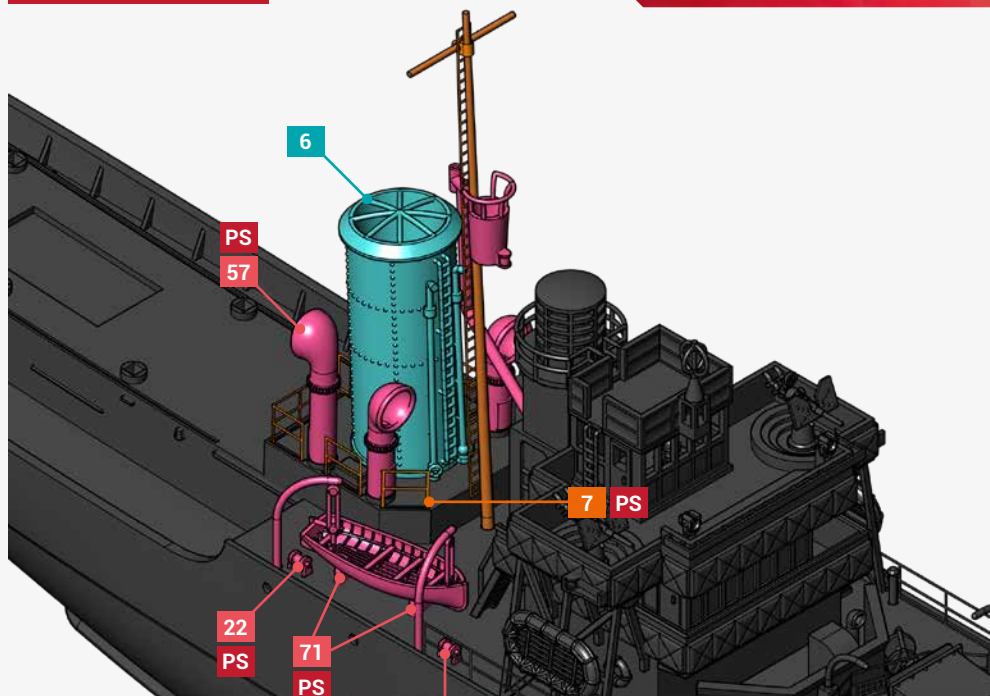

CHECK STEP 4 ON PAGE 13 FOR MORE INFORMATIONS BUILDING THE MAST



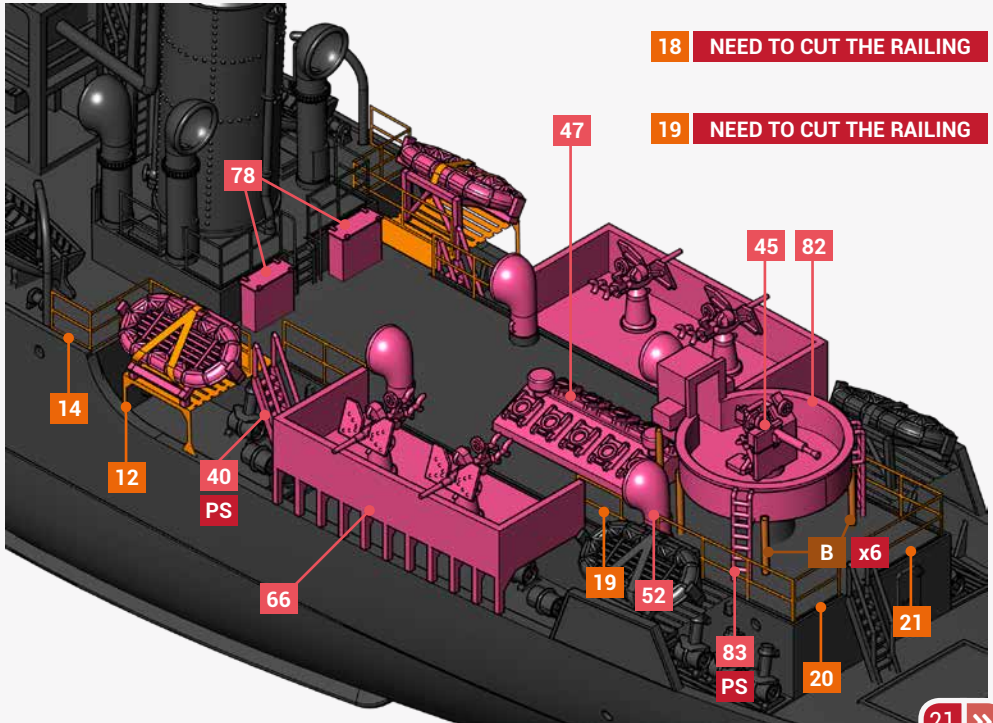
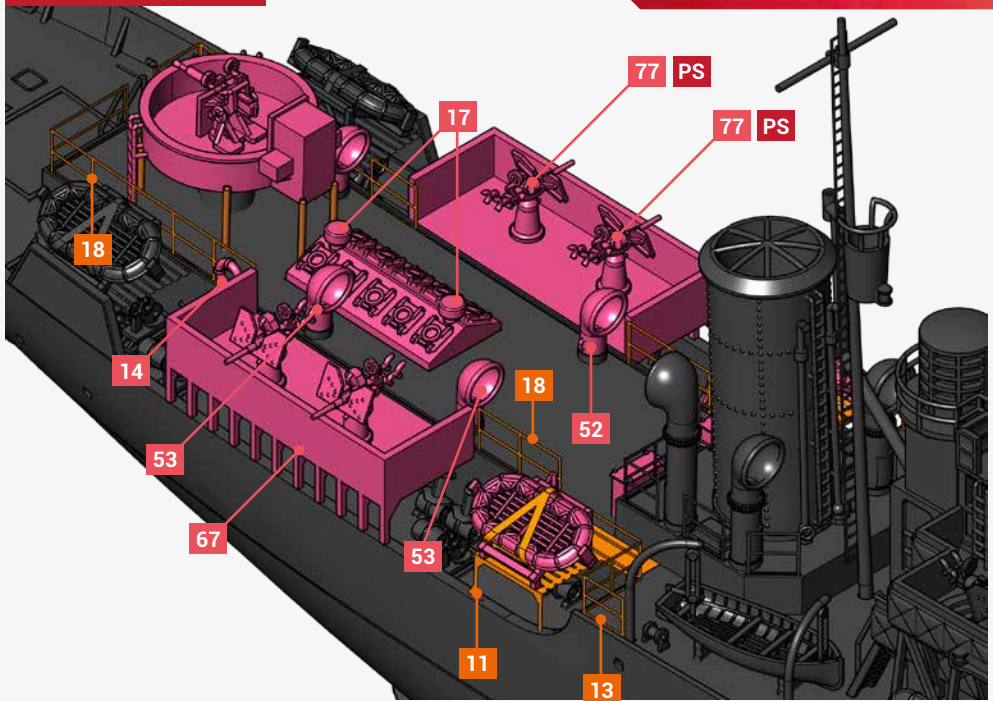

18 NEED TO CUT THE RAILING

19 NEED TO CUT THE RAILING

## STEP 13

ALL VERSION

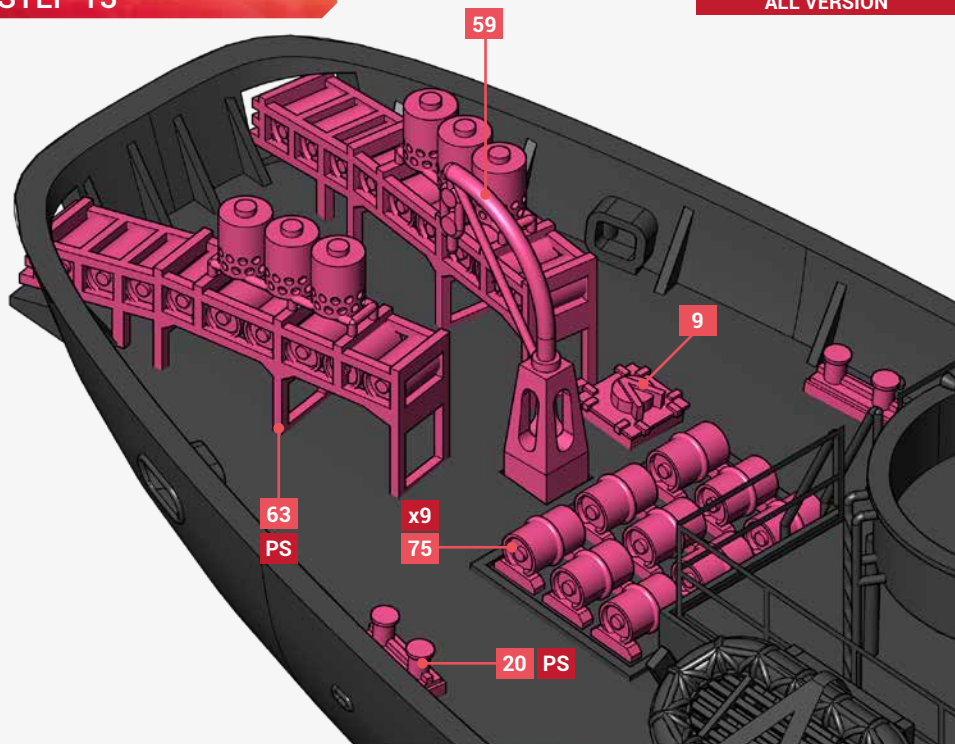

## STEP 14

ALL VERSION

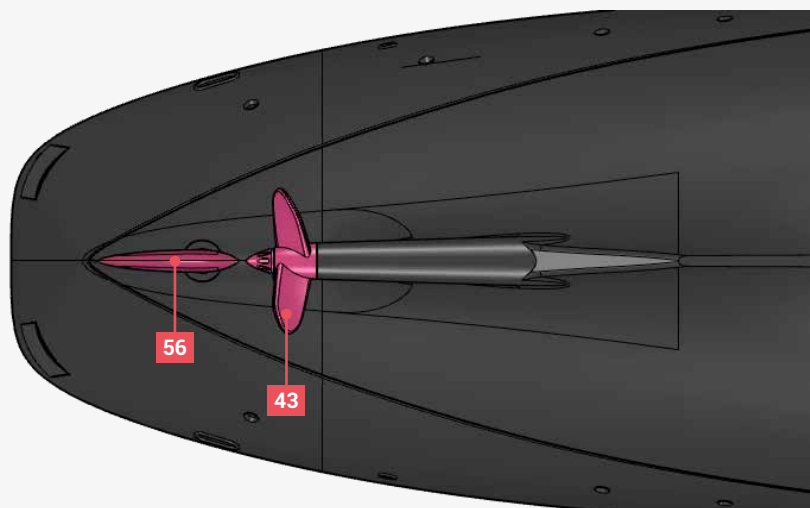

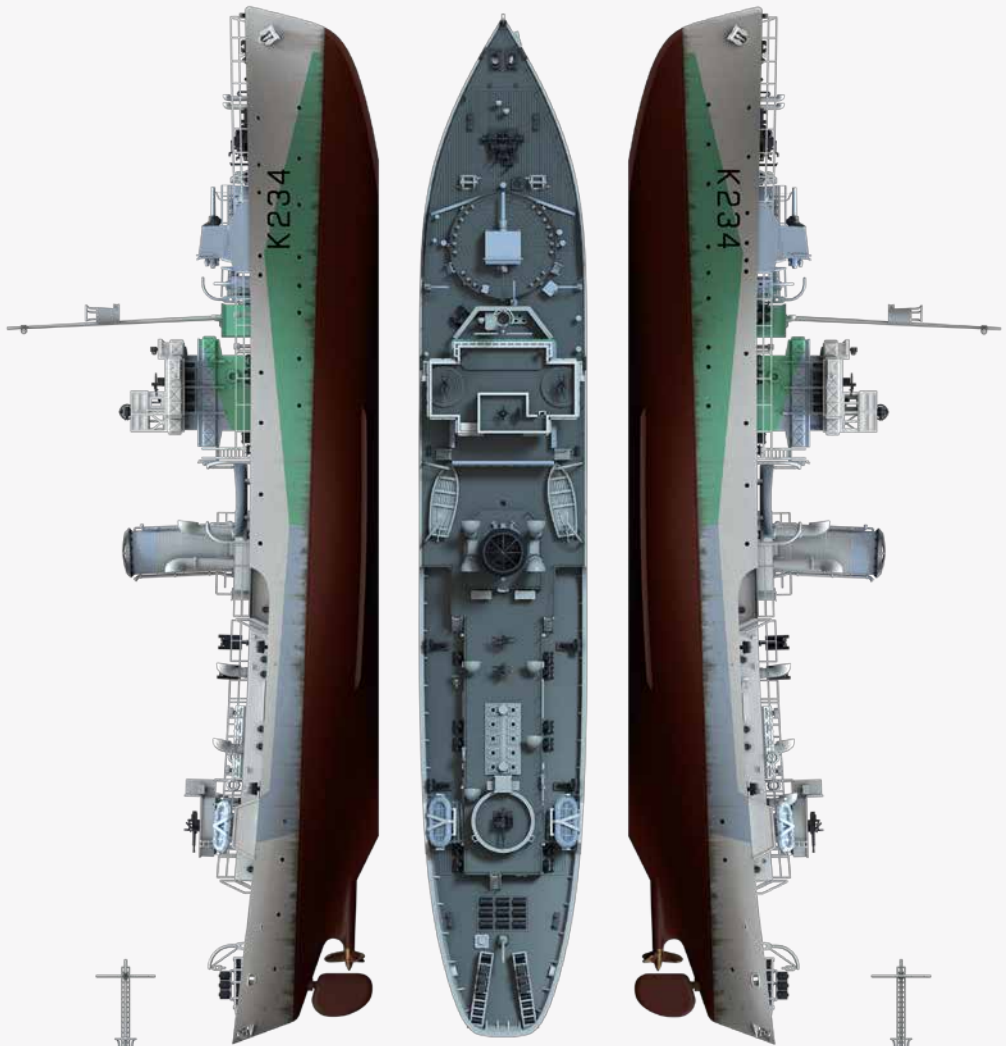

- WHITE
- WESTERN APPROACH GREEN
- WESTERN APPROACH BLUE
- ANTI FOOLING RED

EARLY VERSION

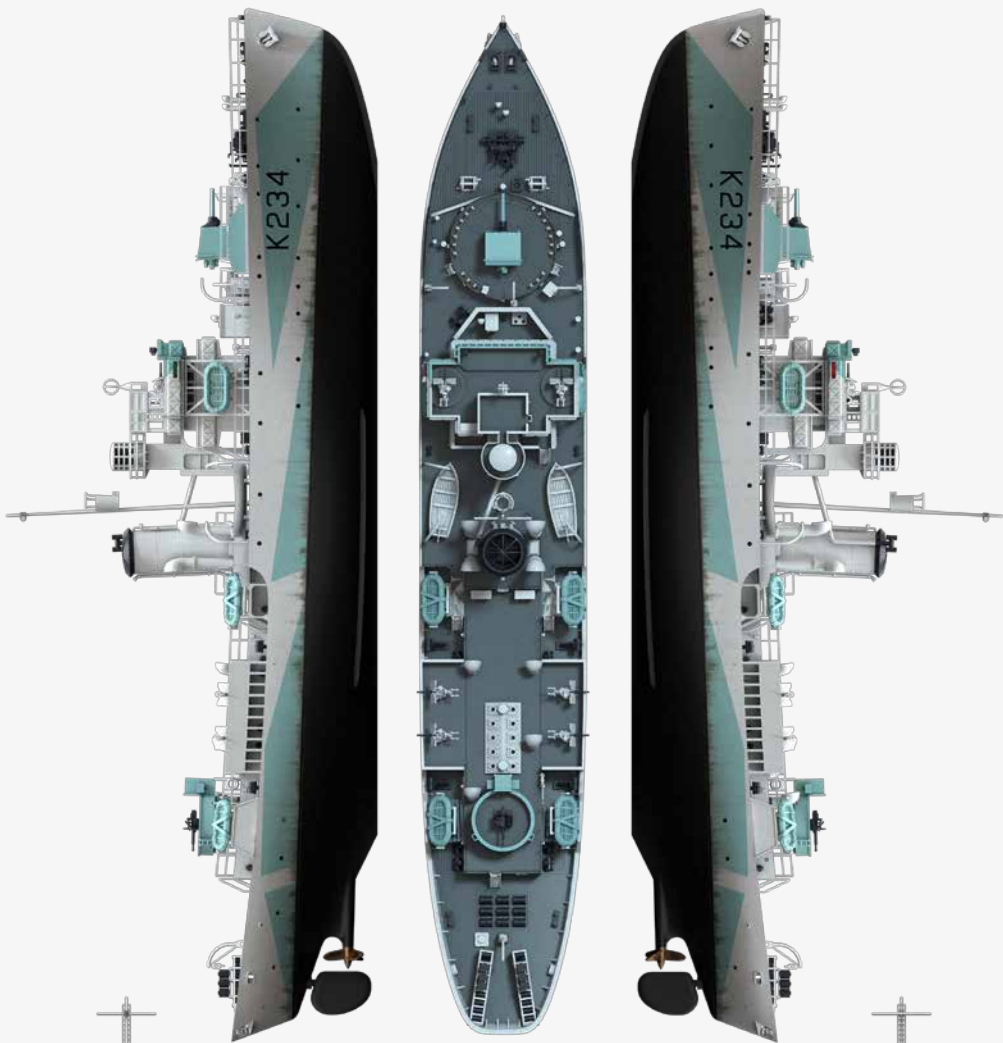

- WHITE
- B55
- BLACK

1944 VERSION