



## HMCS SACKVILLE K181 FLOWER CLASS CORVETTE

When the battle for convoys started in the Atlantic Ocean, Royal Navy was desperately short of escorts to protect the cargo ships against U-boat attacks. An emergency solution was to adapt the design of a whaler into an escort, which led to the birth of the famous Flower class corvettes. First units had a modest armament consisting of a 4-inch gun on the forecastle, a single 40mm pompom amidships and two twin Lewis machine guns on each side of the bridge. ASW armament consisted of four Mk.II depth charges throwers and two depth charges rails on stern. Although handicapped by their low speed of 16 knots, the 294 Flowers that were built bore the brunt of the battle until mid-1943, when new classes of escorts, such as the Rivers and US Destroyer Escorts, began to be available.

HMCS Sackville was the second Flower class corvette ordered by the Royal Canadian Navy. She was launched on May 15, 1941 in St. John, New Brunswick and commissioned on December 30, 1941. Sackville escorted 30 Trans-Atlantic convoys during her wartime career. Sackville's actions escorting Convoy ON-115 damaged three U-Boats attempting to engage that convoy, forcing them to break off their attacks. Postwar, Sackville was converted to a research vessel for the Canadian Department of Marine and Fisheries, serving in that capacity until December 1982. Sackville was the only remaining Flower class corvette and she is currently a museum ship in Halifax, Nova Scotia after being fully restored.

XX	RESIN PARTS
XX	3D PARTS
XX	PHOTOETCH PARTS
XX	BRASS PARTS
XX	DECALS PARTS

!	ASSEMBLY WARNING
PS	PORT & STARBOARD
P	PORT SIDE
S	STARBOARD SIDE
X	INFORMATIONS

SOME PHOTOETCH AND 3D PARTS ARE PROVIDED IN EXTRA NUMBERS.

**IMPORTANT ! PLEASE FULLY READ THE INSTRUCTIONS BEFORE STARTING THE BUILD !**

## DECALS

KI8I KI8I KI8I ♣ KII  
 KI66 KI66 KI66 KII  
 KI66 KI66 KI66 KII  
 K0123456789  
 K0123456789  
 K0123456789  
 K0123456789  
 K0123456789  
 K0123456789  
 K0123456789  
 K0123456789  
 K0123456789

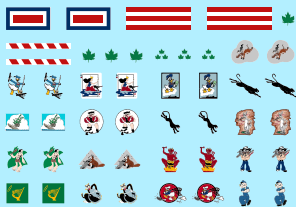

SOME 3D AND BRASS PARTS ARE PROVIDED TO CONSTRUCT AN ALTERNATE VERSION OF THE SHIPS.

## PHOTOETCH

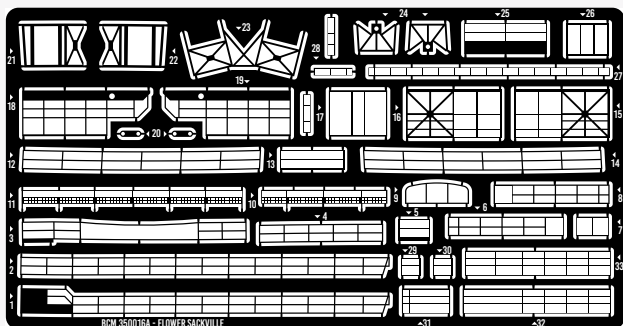

## BRASS

NOT USED >

A	x1	Ø=0.83mm L=42mm
B	x6	Ø=0.4mm L=4mm
C	x1	Ø=0.4mm L=10mm
D	x1	Ø=0.4mm L=13mm

## PARTS

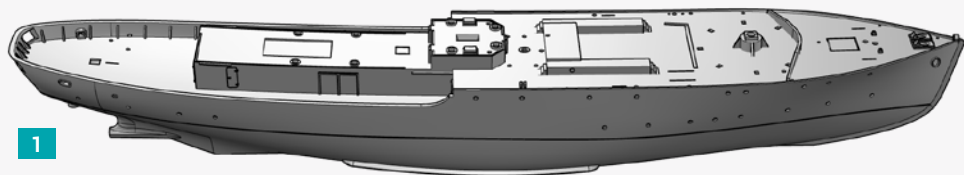

1

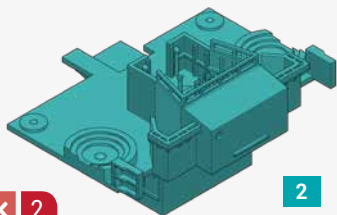

2

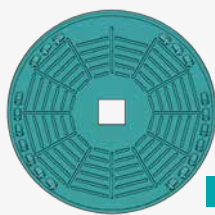

3



4

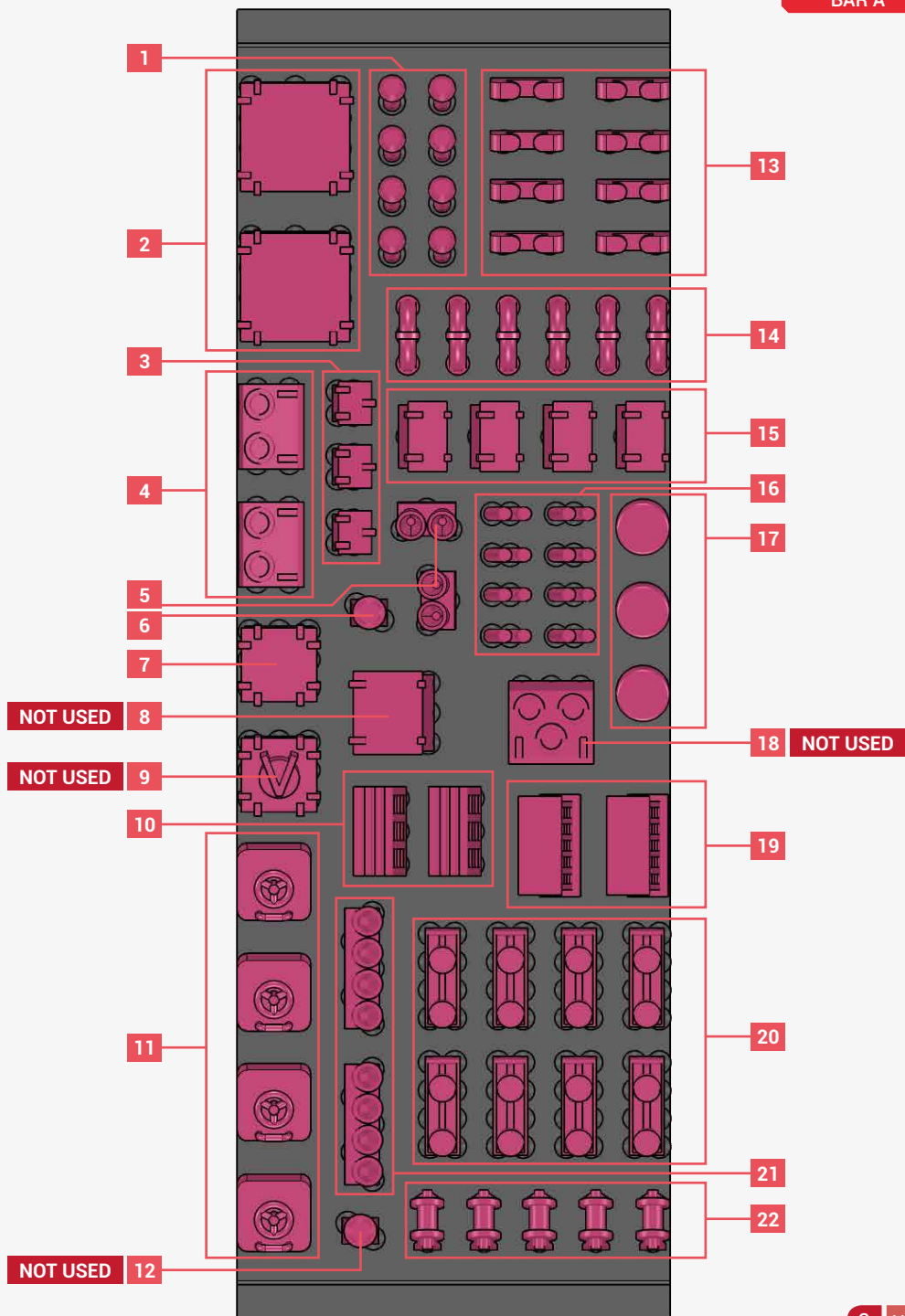

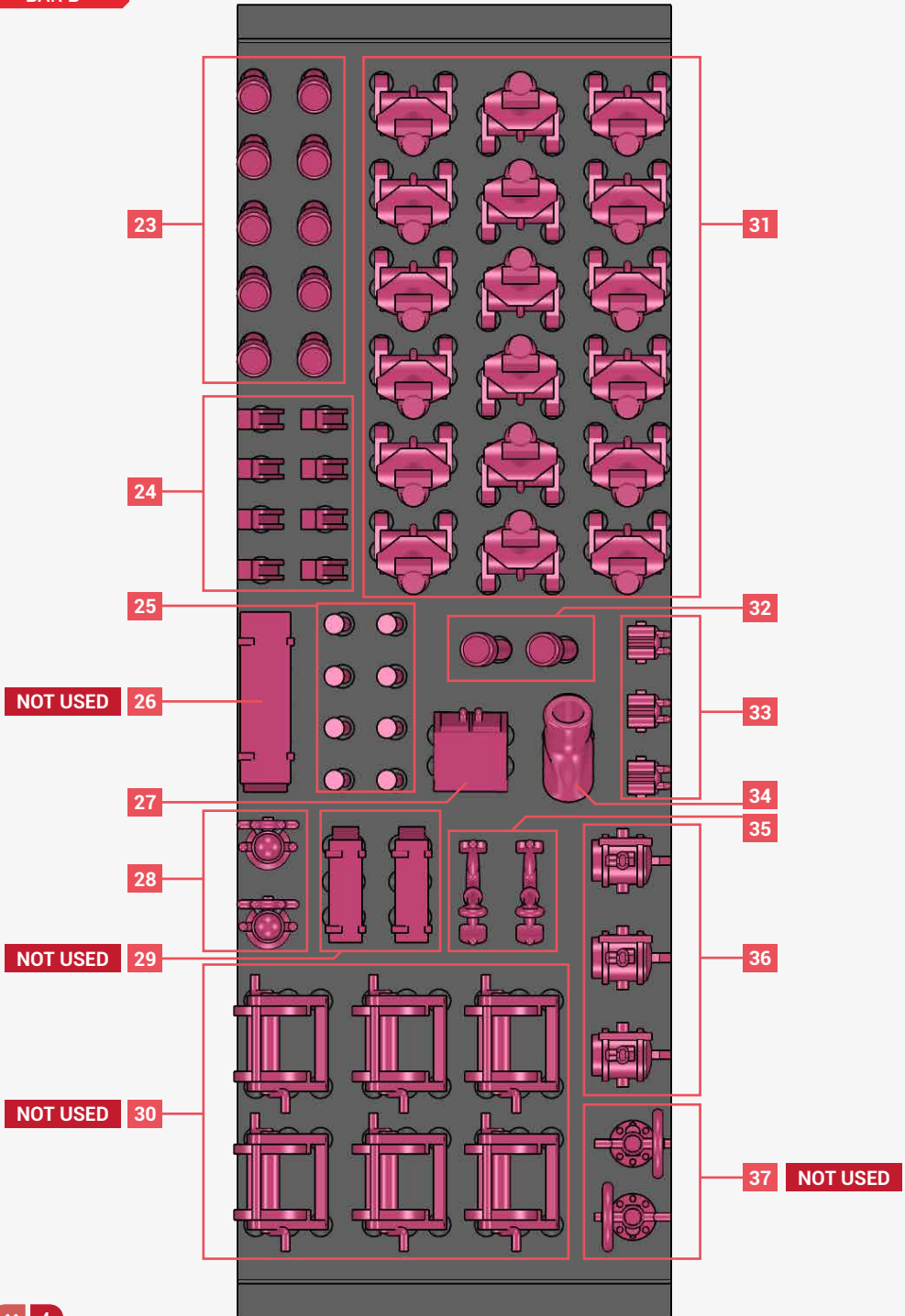

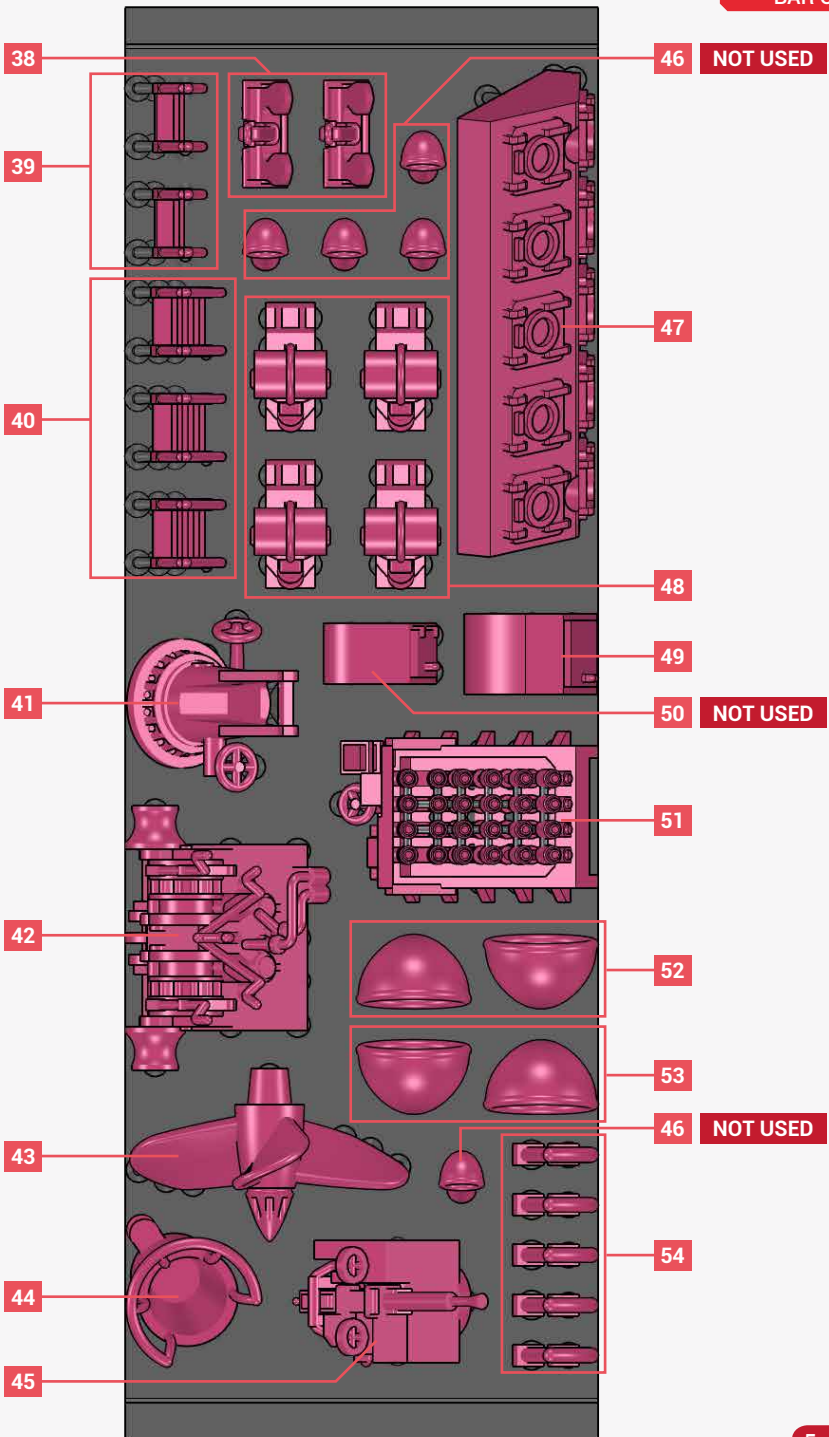



NOT USED 55

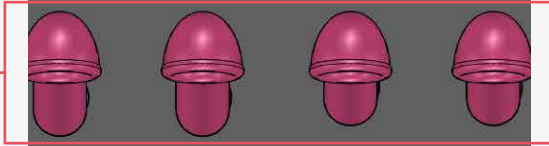

56



59

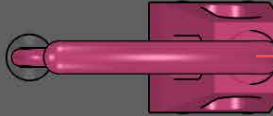

60

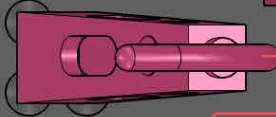

61

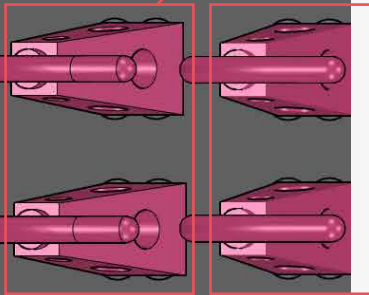

62 NOT USED

57

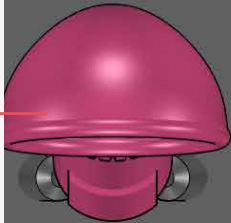

57

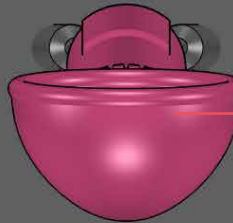

58

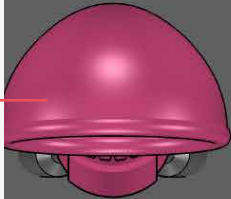

58

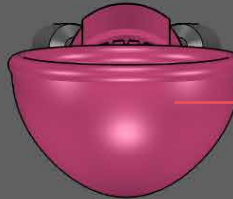

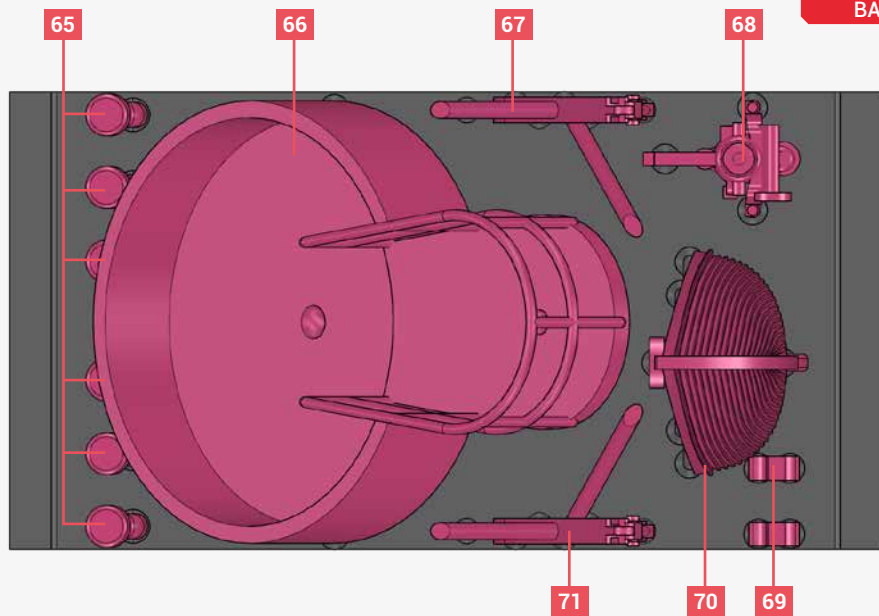
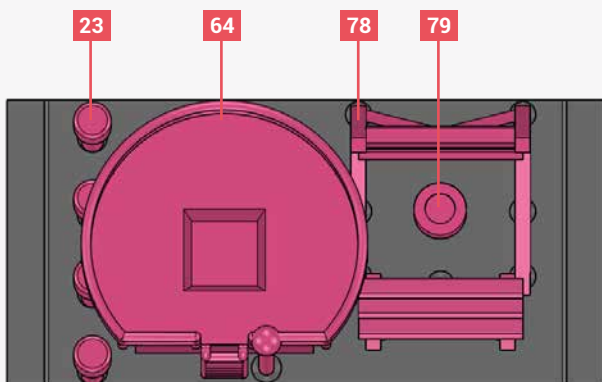
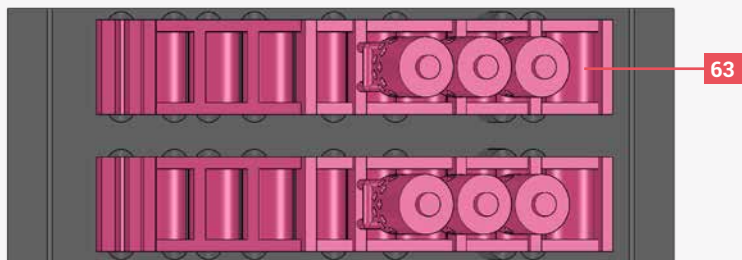

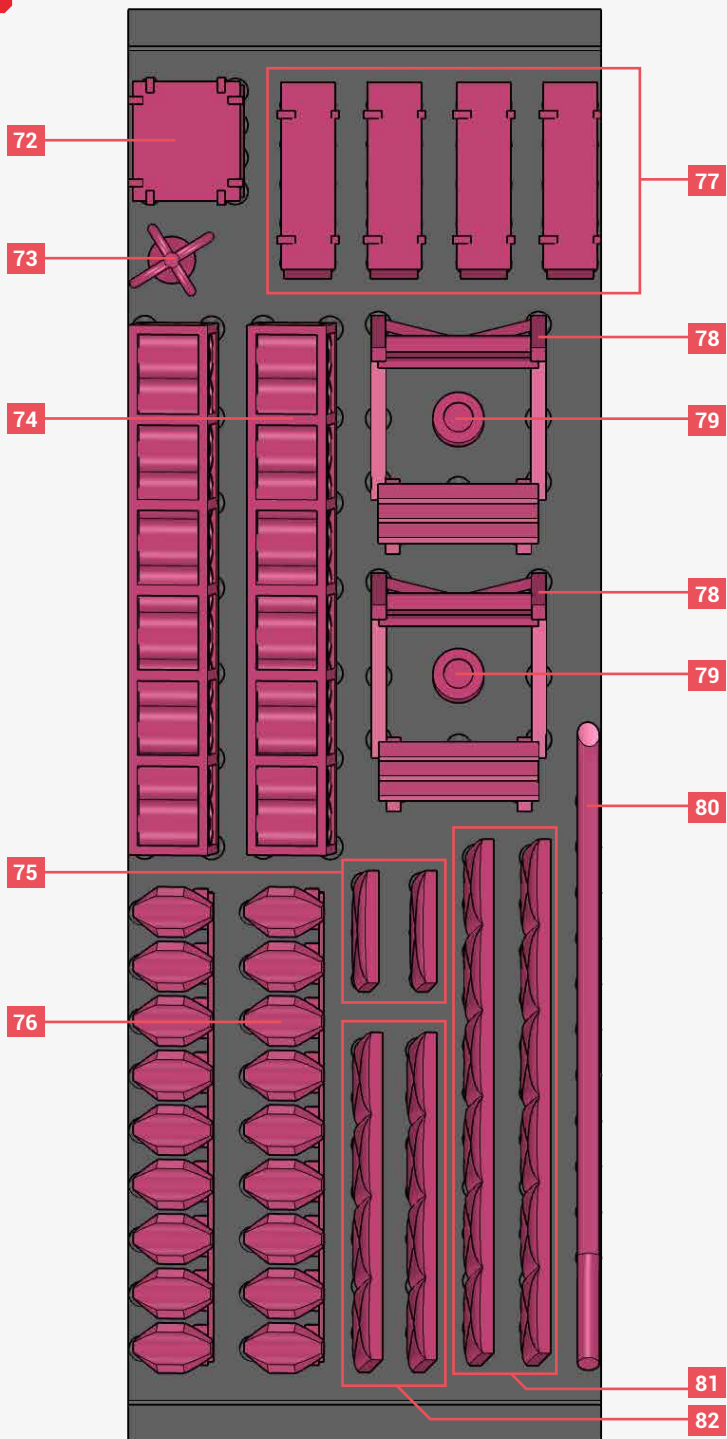



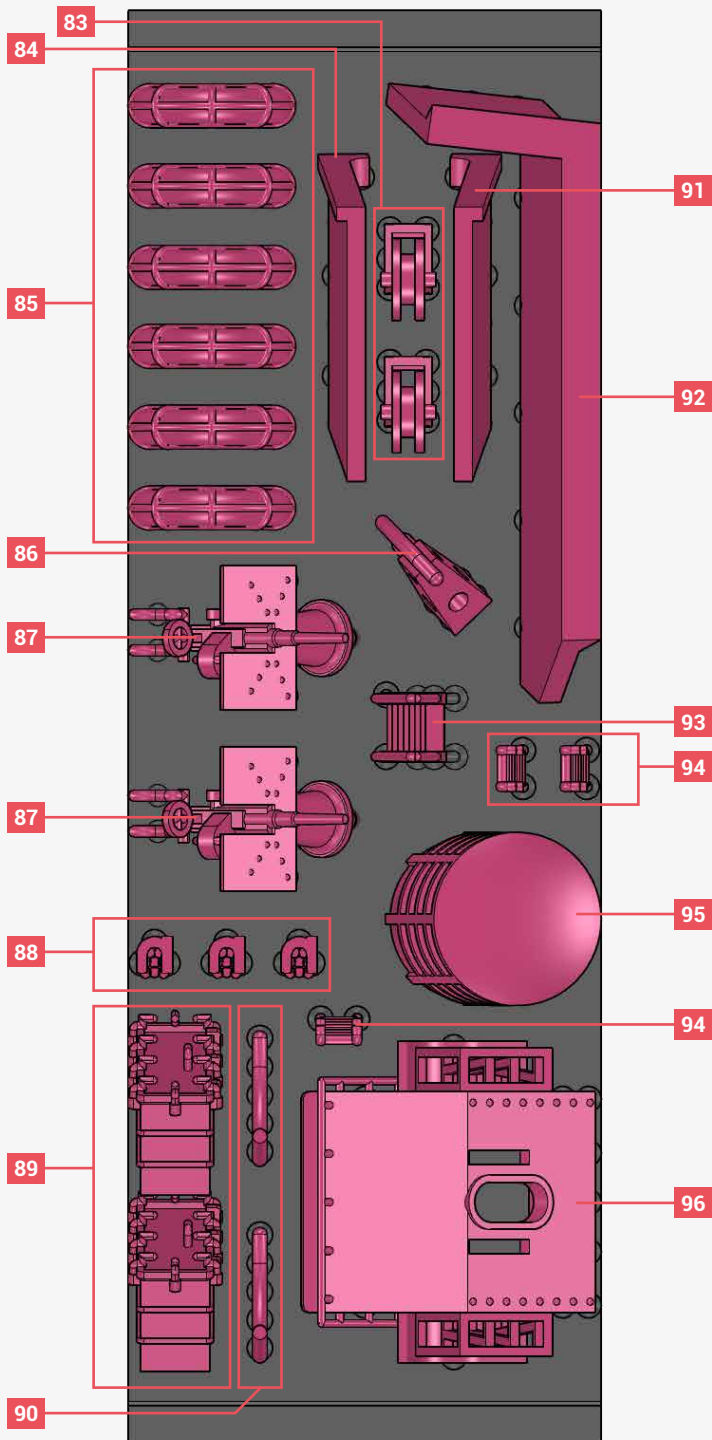

## STEP 1

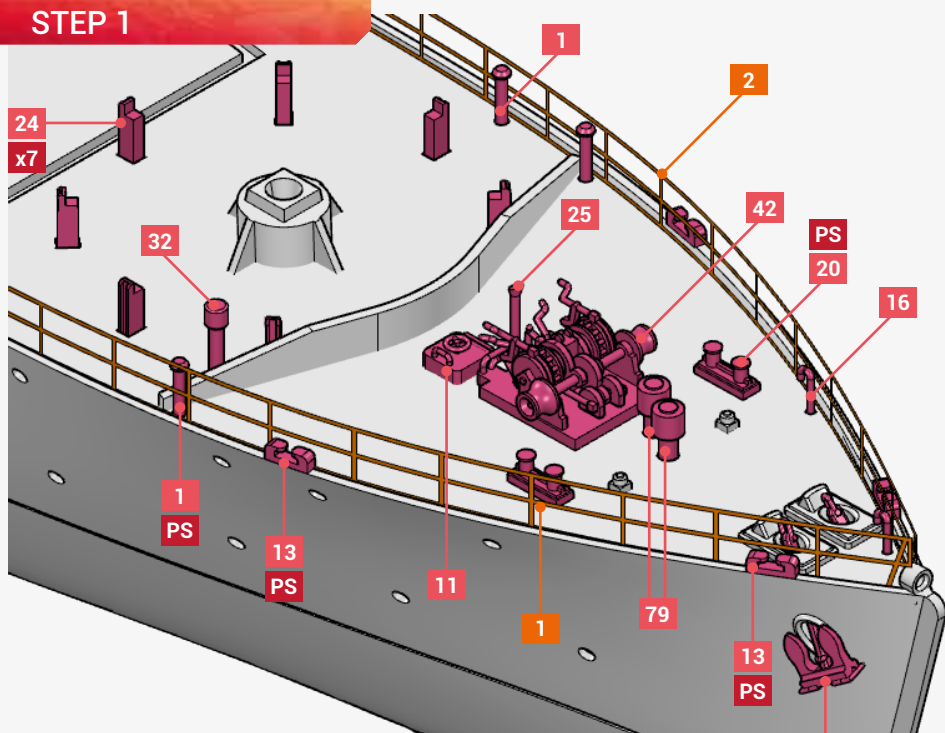

## STEP 2

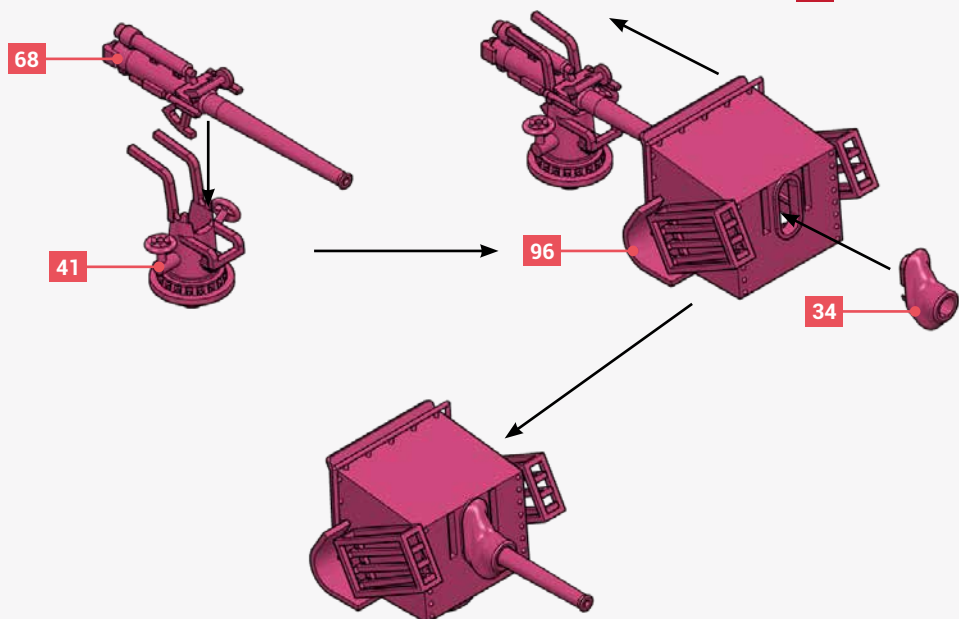

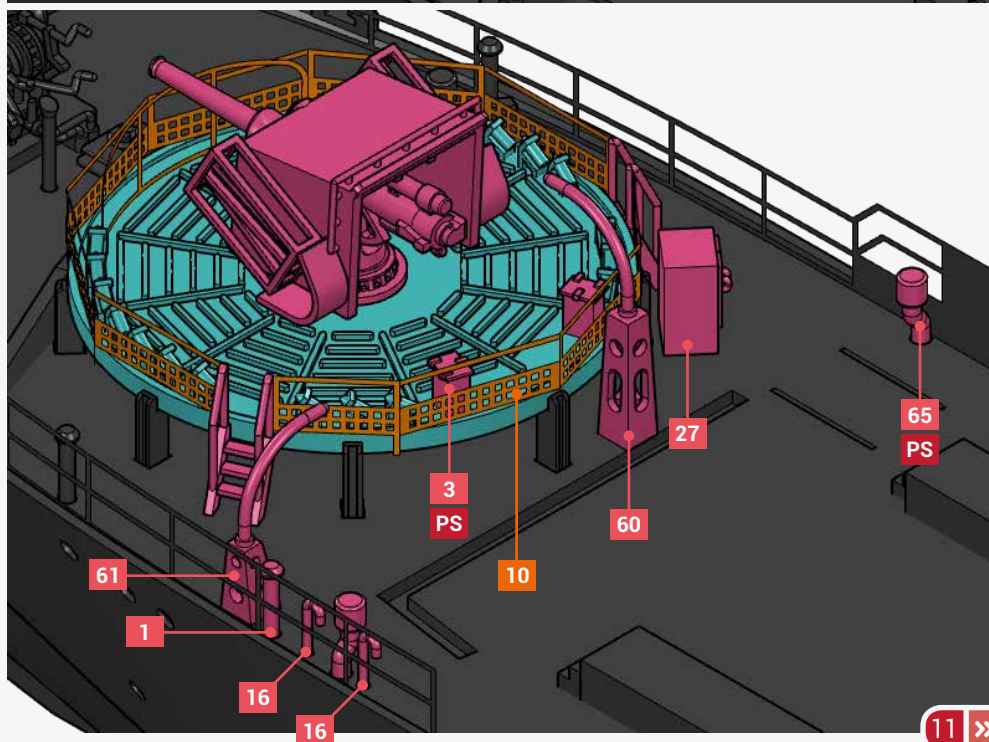
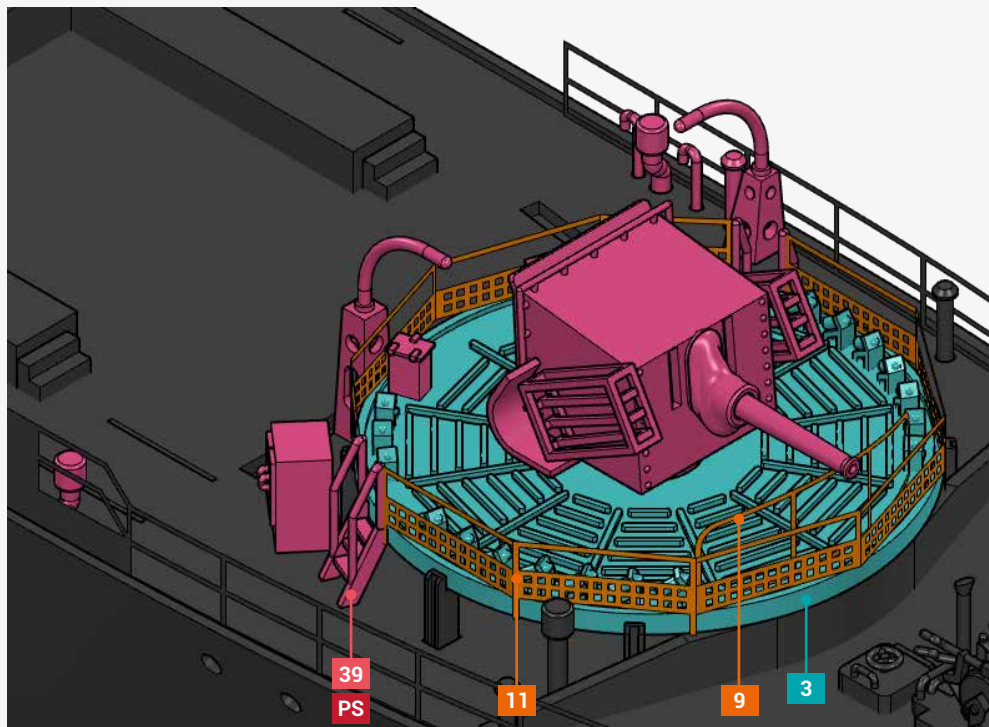



### STEP 3

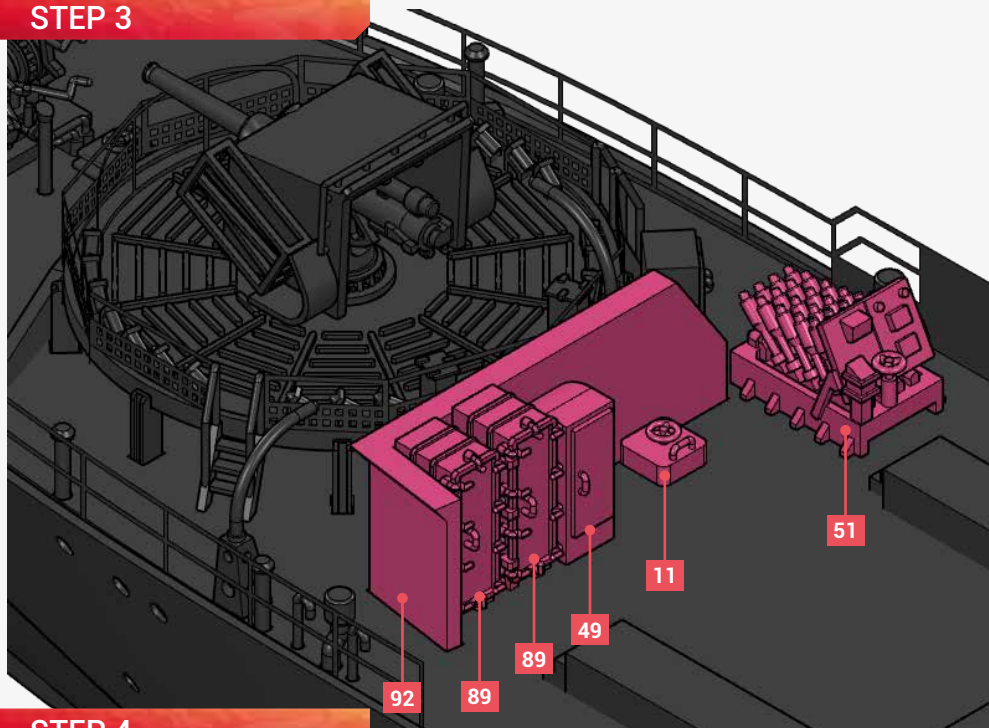

### STEP 4

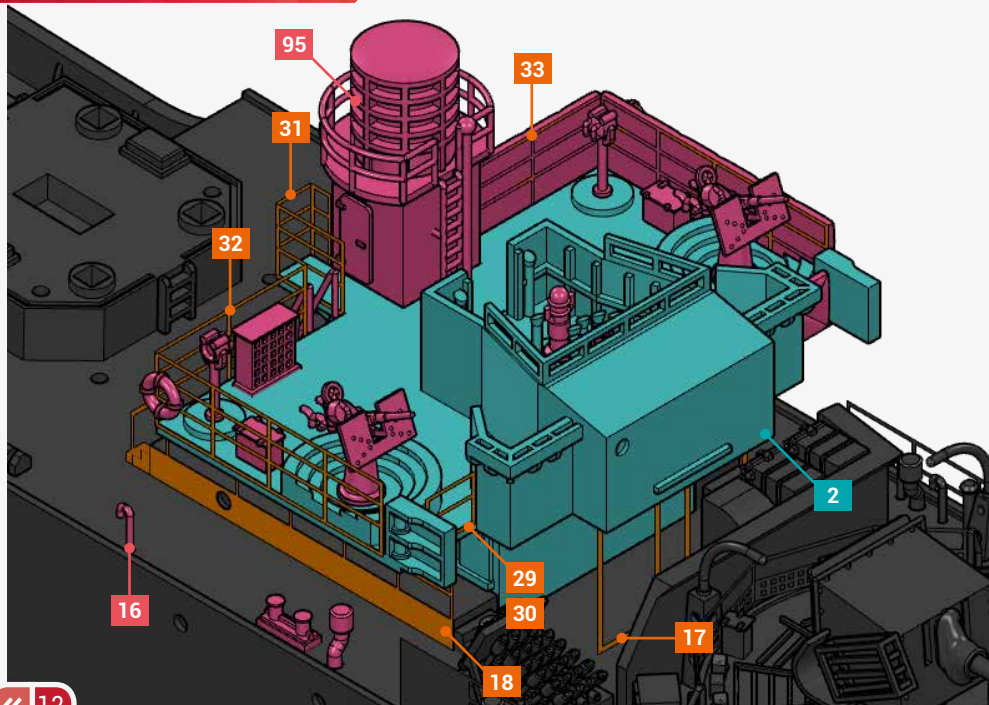

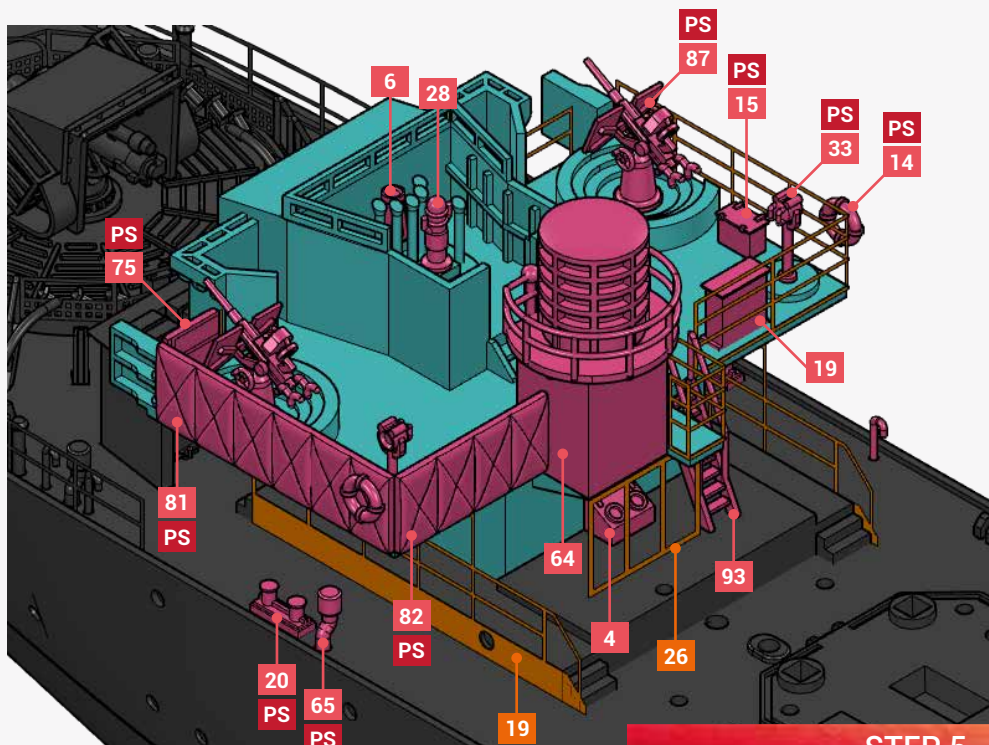

## STEP 5

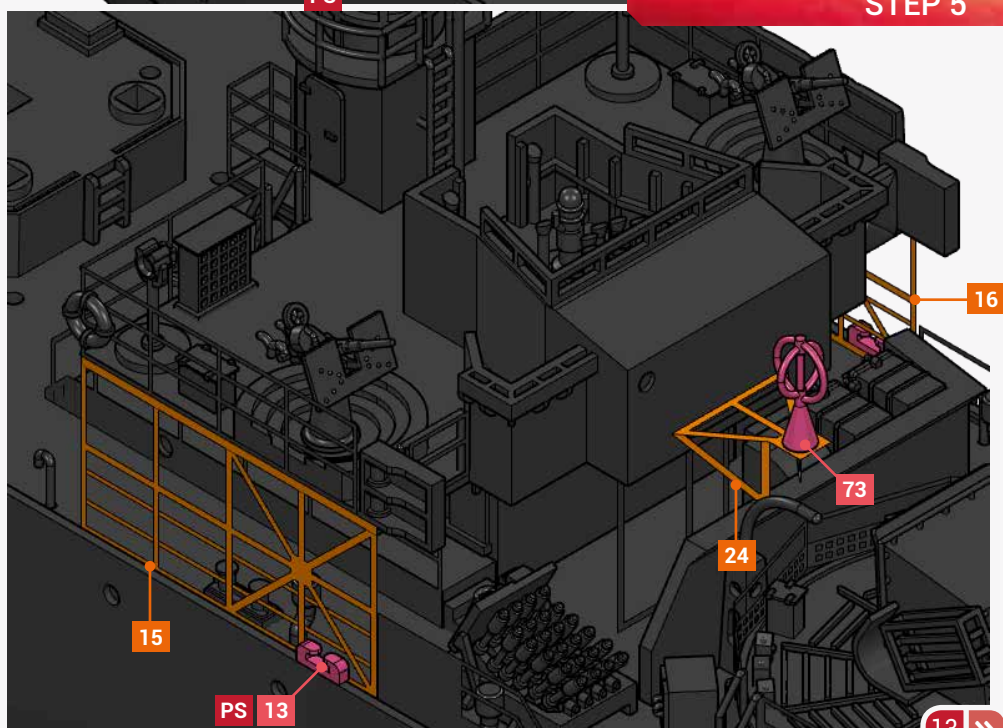



# STEP 6

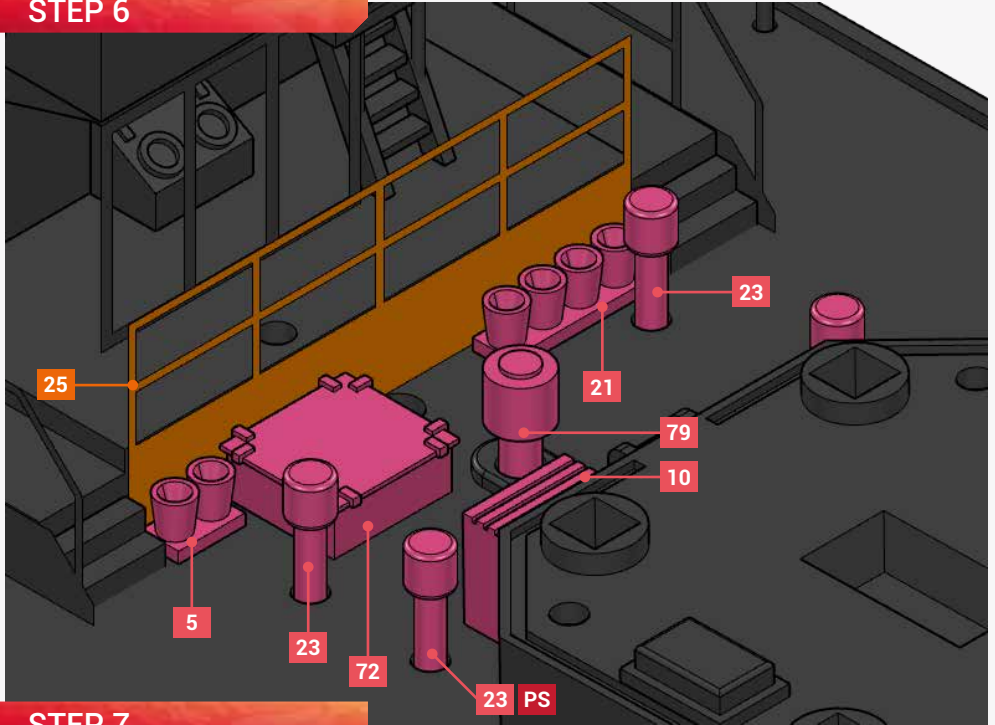

# STEP 7

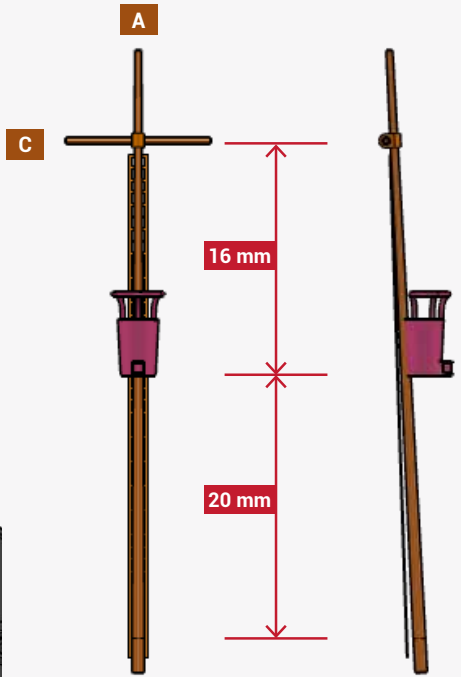
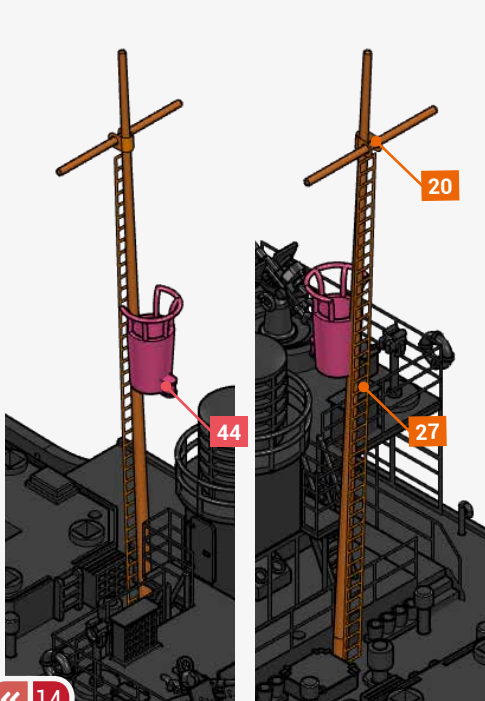

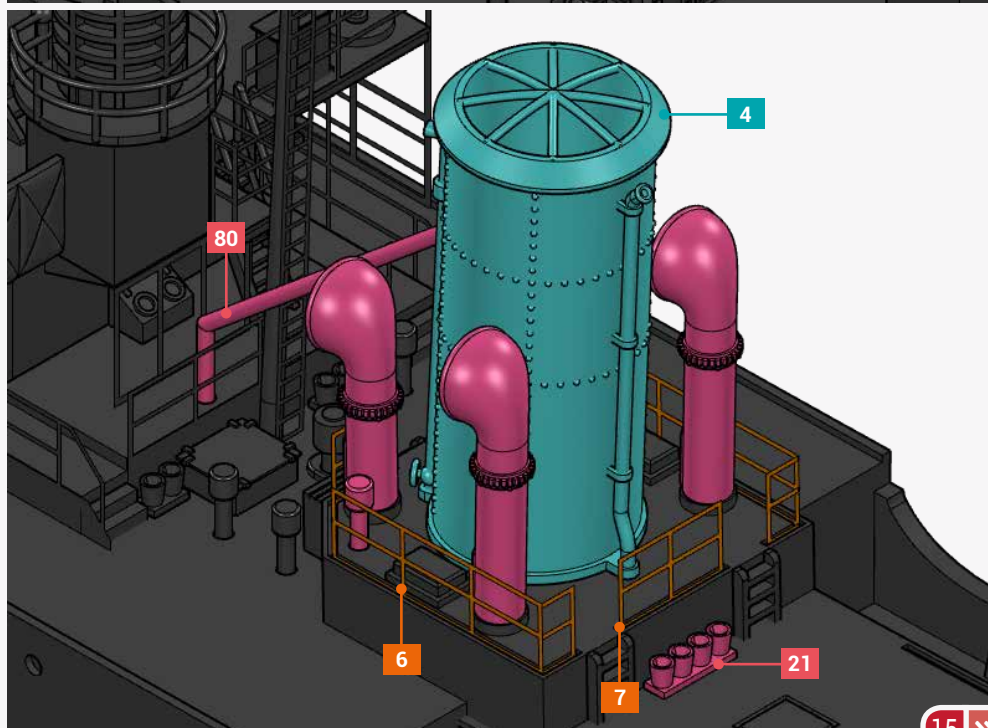
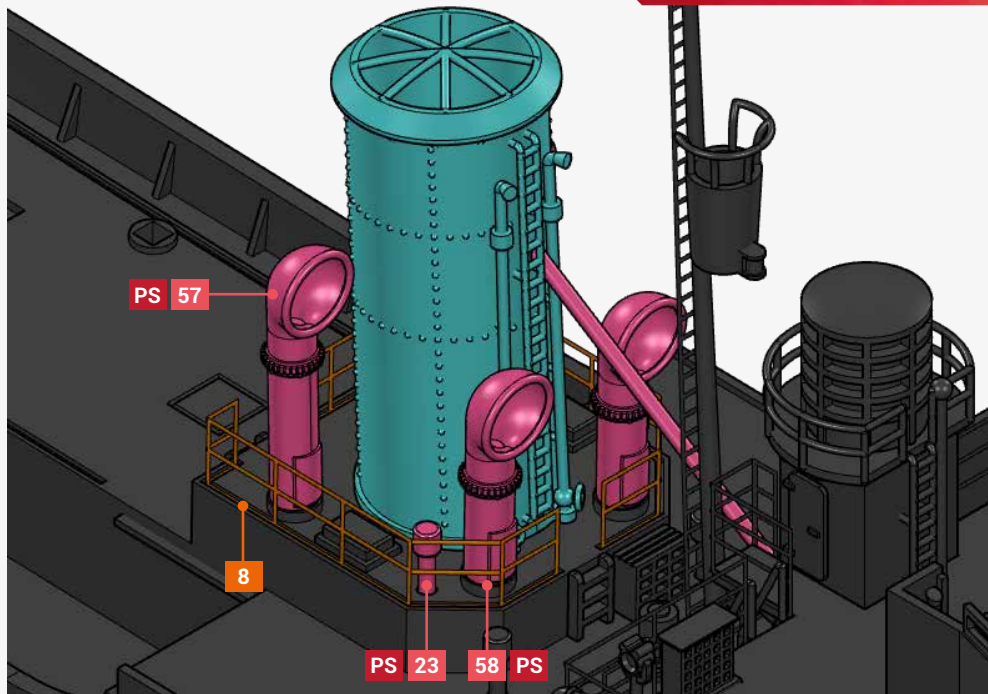

# STEP 9

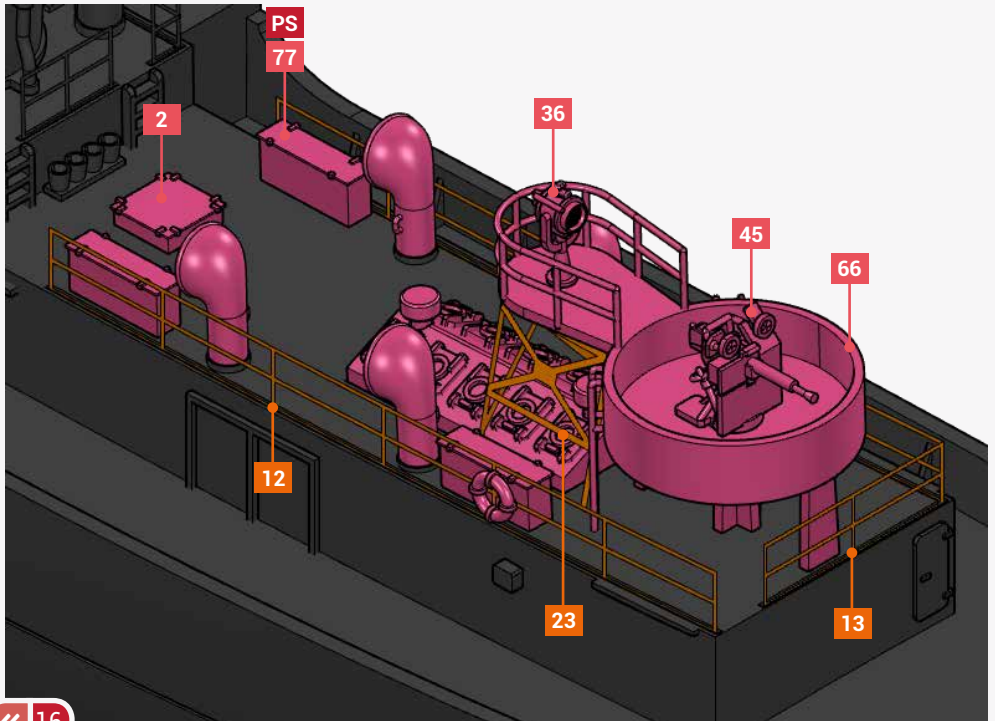
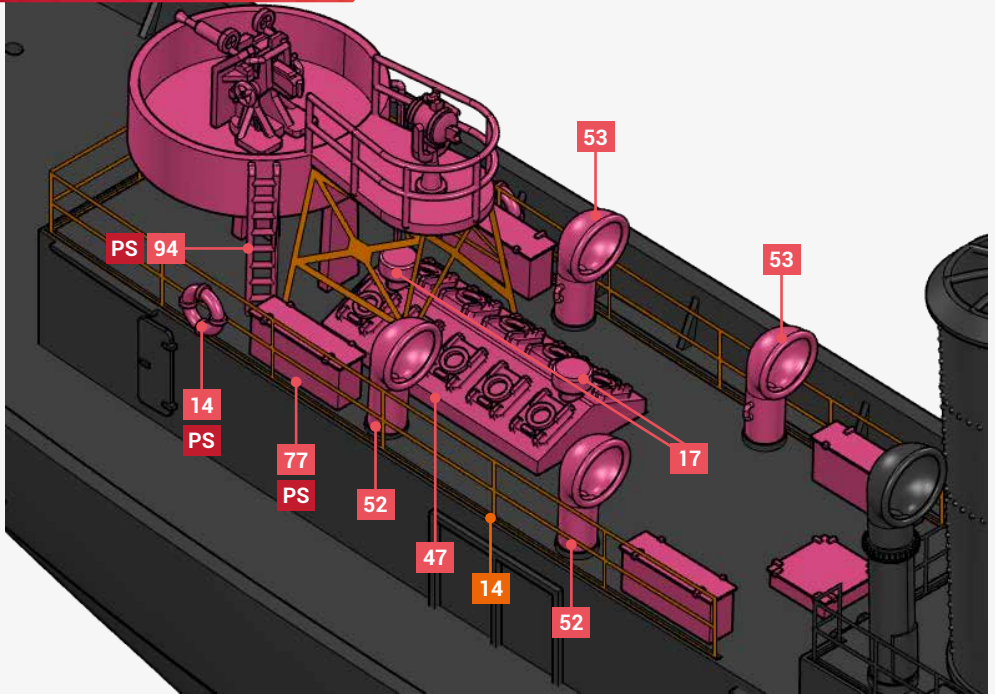



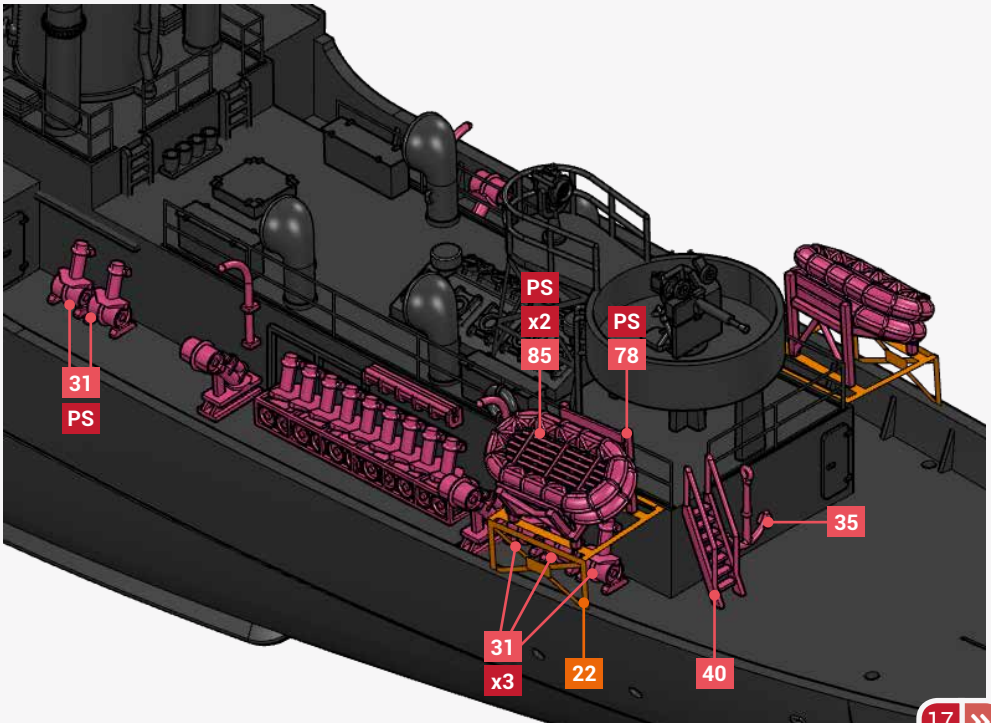
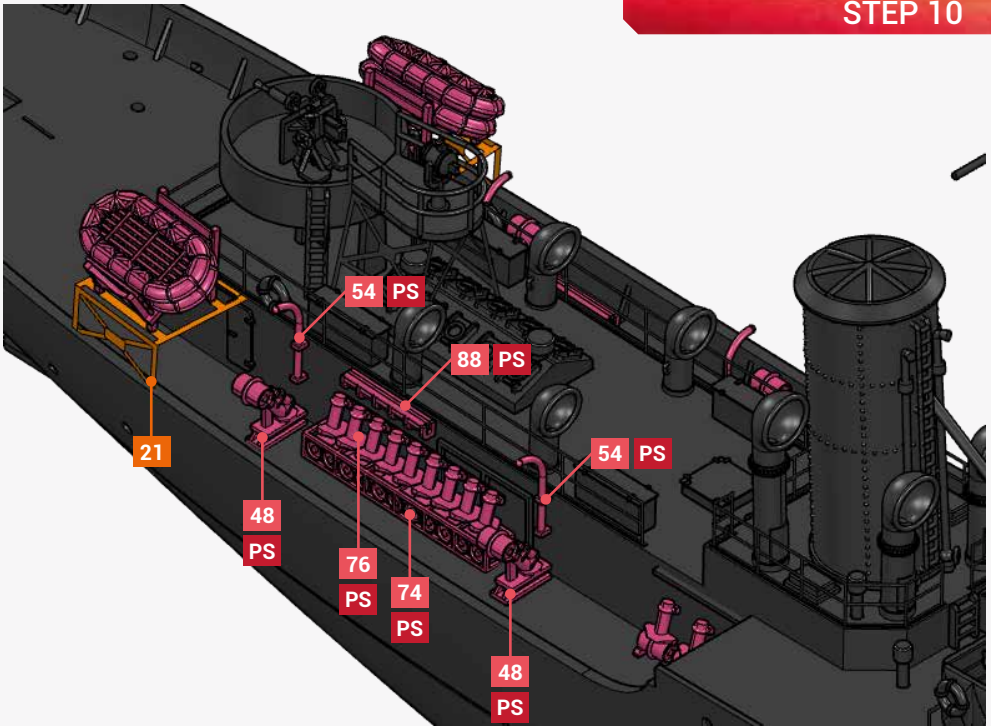

# STEP 11

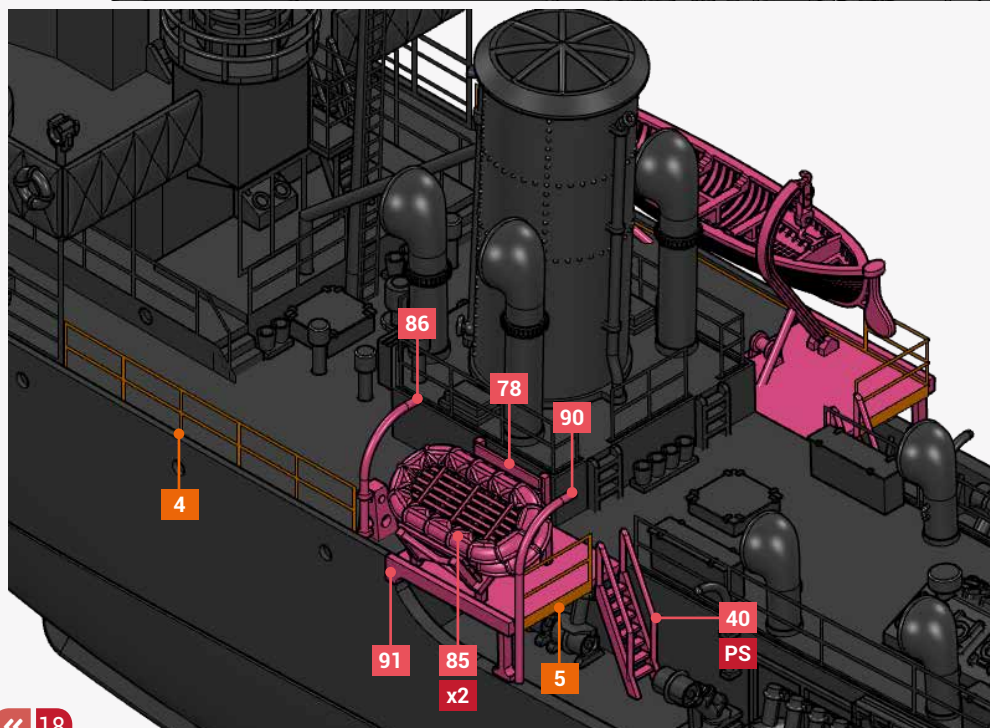
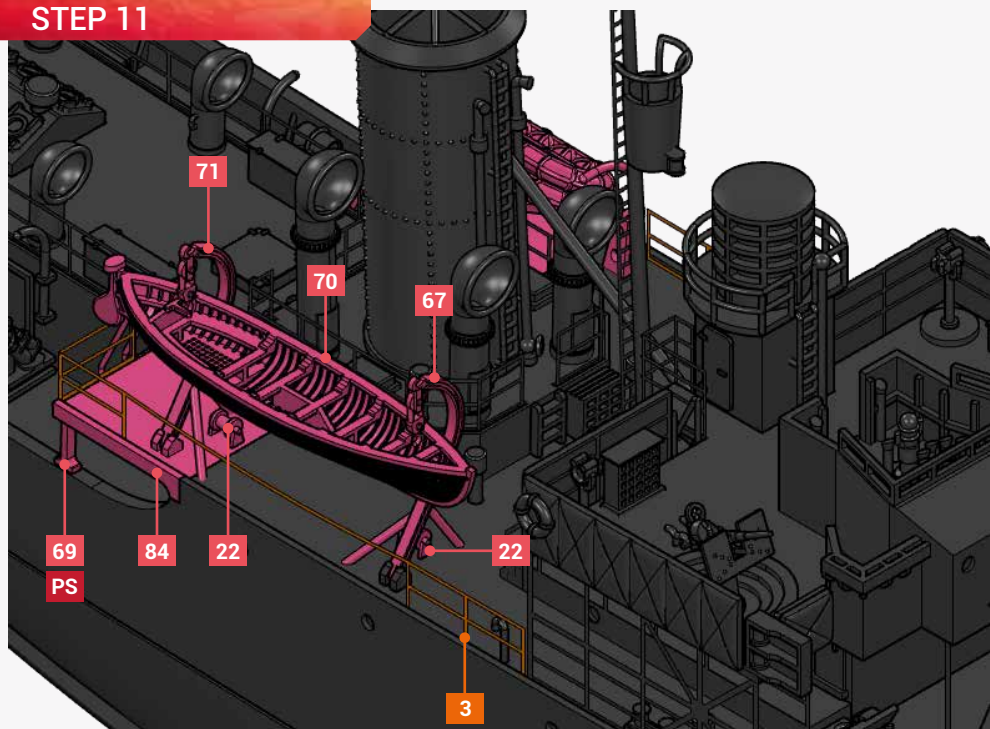



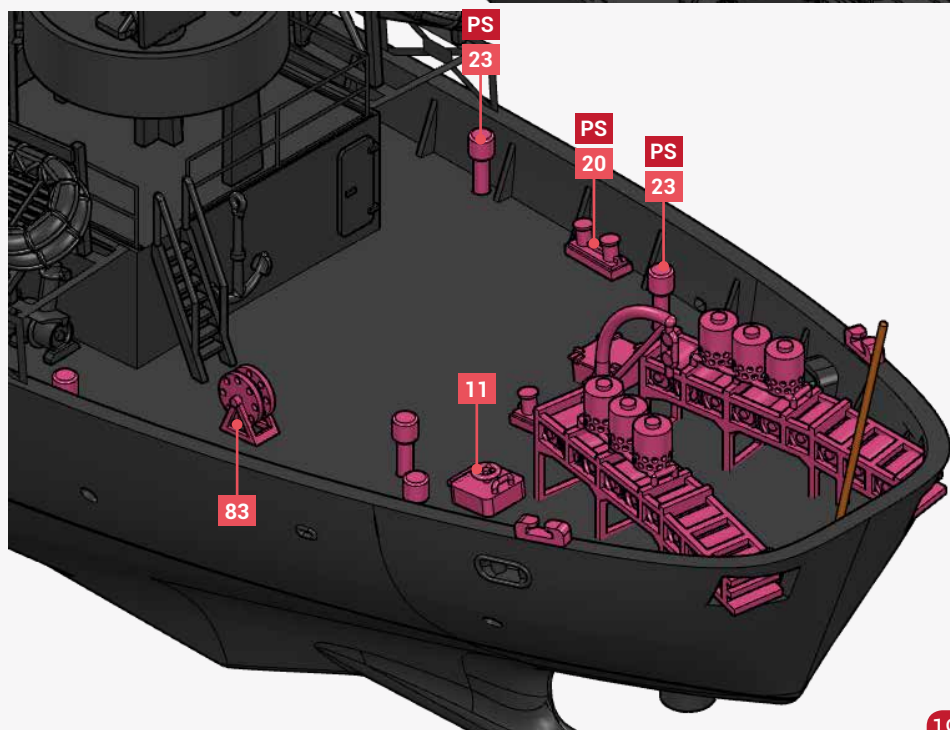
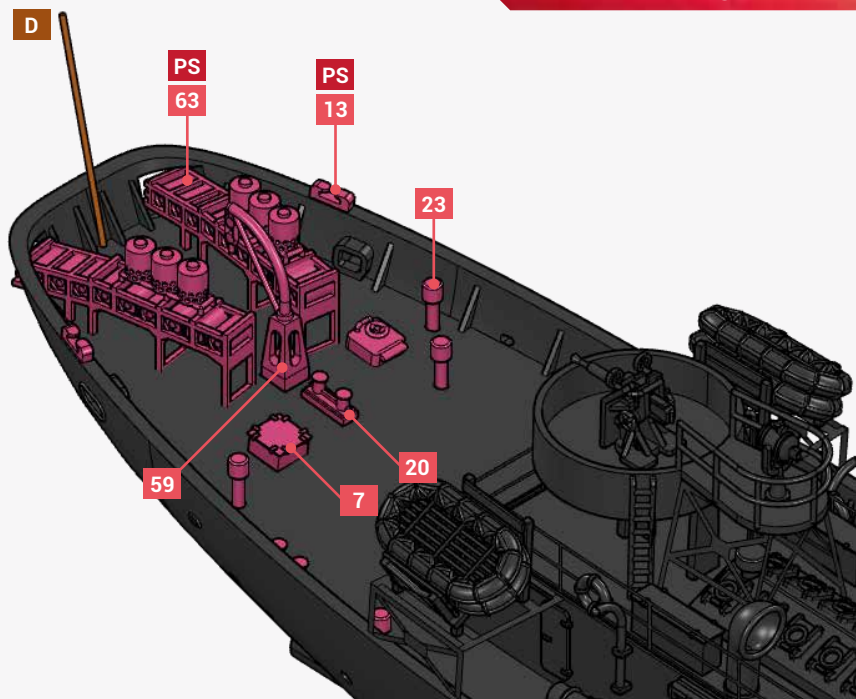

## STEP 13

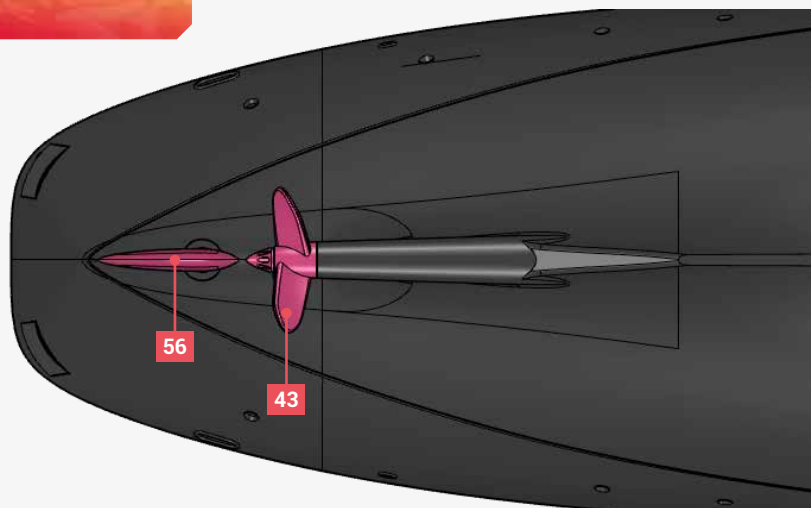

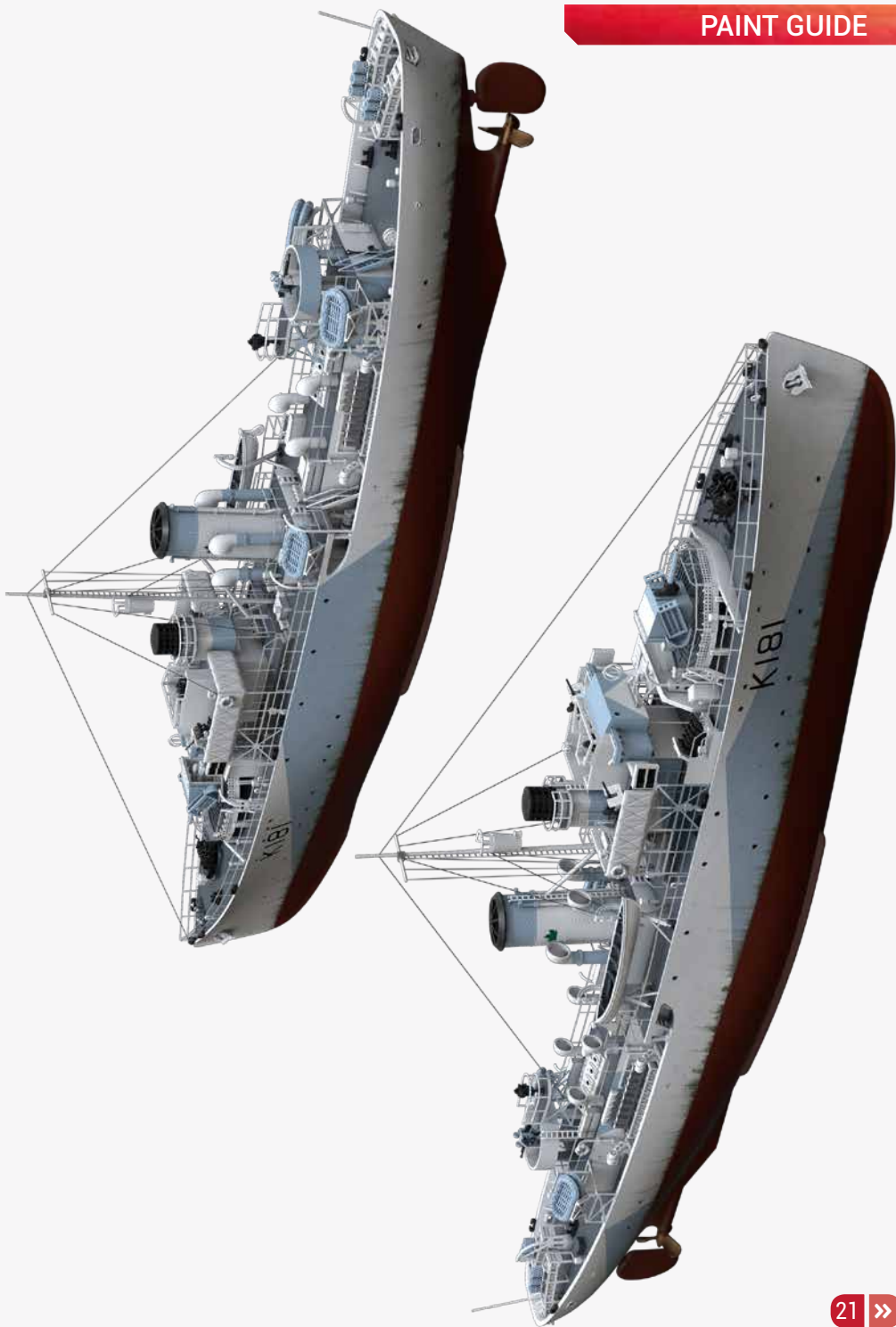

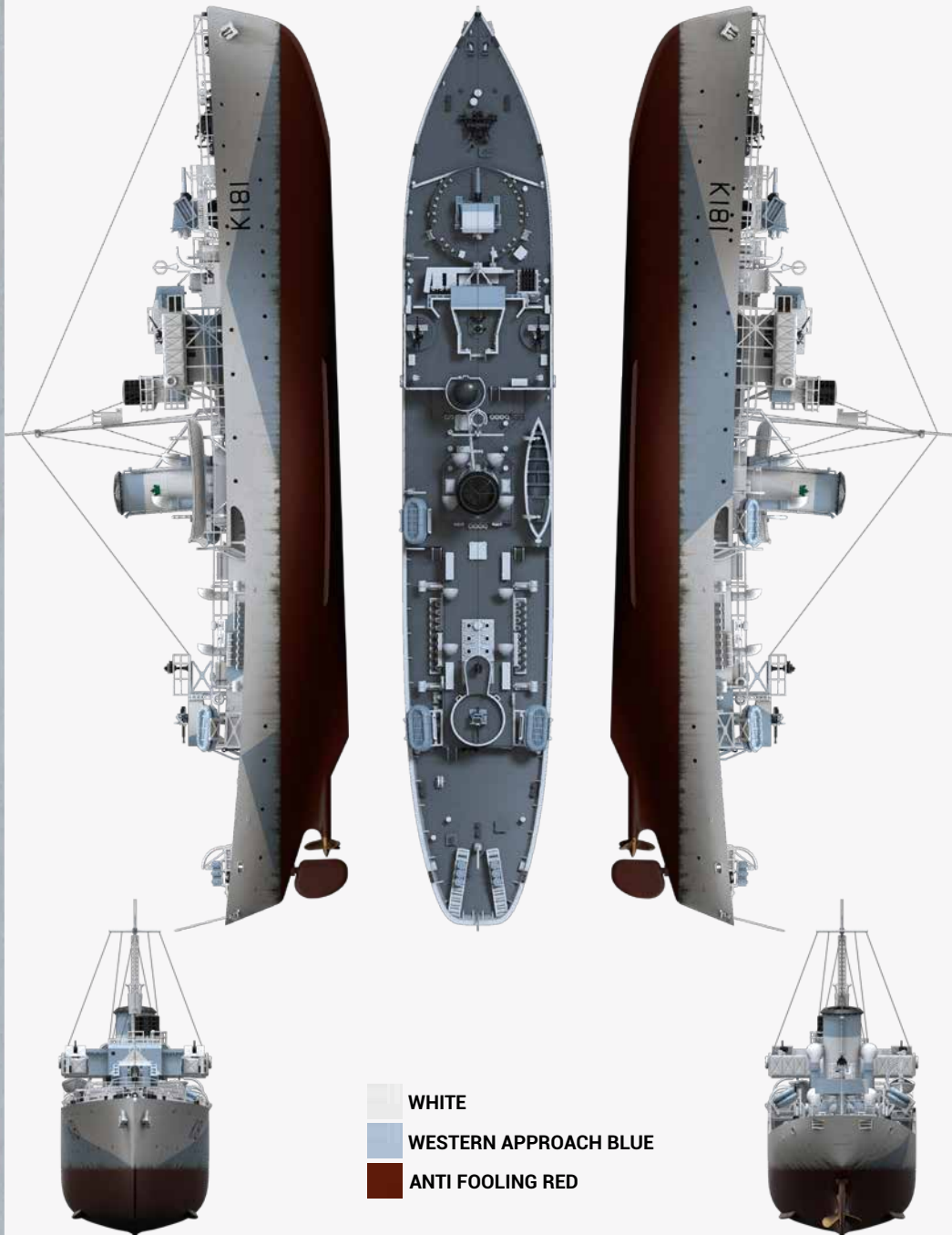



MEMORIAL NAVAL  
CANADIEN



**HMCS Sackville** was built in Saint John, New Brunswick and named after the town of Sackville, NB. The ship was commissioned into the Royal Canadian Navy (RCN) in December 1941 and is the last of 123 Canadian built wartime corvettes that, along with other RCN ships and units from the RCAF Maritime Coastal Command, played a major role in the Allies' victory at sea in the Battle of the Atlantic (1939-1945).

**Flower Class Corvette Characteristics**

- > Displacement: 950 tons.
- > Length: 205 feet/62.5 m.
- > Top speed: 27.50 ship=16 knots.
- > Propulsion: single screw 4 cylinder vertical triple expansion engine, 2 scotch boilers.
- > Armament: 1 breech loading 4 inch/102 mm Mark 1X(9) gun (ship's main armament).
- 1 quick firing MK.VIII 2 pounder (pom pom) on anti-aircraft mount.
- 2-20mm Oerlikon anti-aircraft cannon.
- 4 Depth charge throwers and stern rails.
- 1 Hedgehog (mortar) anti-submarine projector.
- > Type 271 Radar (detect and track submarines on the surface/other enemy vessels).
- > ASDIC (anti submarine detection investigation)/SONAR.
- > Crew: Up to 85 (officers and men).

**The Battle of the Atlantic**

Following the declaration of war in 1939 and Allied setbacks in Europe, Great Britain faced the threat of invasion by German forces and stood alone. The sea lanes extending eastward across the North Atlantic from Canada and the United States were Britain's lifeline for much of its food, fuel, war materiel and raw materials. The Allies' convoy system of merchant vessels escorted by naval ships and maritime aircraft maintained the lifeline against deadly enemy U-boat wolf packs.

**HMCS Sackville** and other ships of the rapidly expanded Royal Canadian Navy operating out of Halifax, St John's and other East Coast ports were front and centre during the lengthy war at sea. **HMCS Sackville's** most memorable encounter occurred in August 1942 when it engaged three U-boats in a 24 hour period while escorting a convoy that was attacked near the Grand Banks off Newfoundland. K181 put two of the U-boats out of action before they were able to escape. A year later as part of another convoy that was attacked by U-boats **HMCS Sackville** chased and drove down one submarine with depth charges; several merchant vessels and four naval escorts were torpedoed and sunk with heavy loss of life. In the summer of 1944 after being part of the largest (166 ship) convoy of the war **HMCS Sackville** was relieved of escort duties (due to a damaged boiler) and served as a training ship for HMCS Kings officer training establishment and as a harbour loop layer. Following the end of hostilities **Sackville** was converted and continued to serve as a naval and oceanographic research vessel until paid off in 1982. During the war the RCN sustained the loss of 24 ships and more than 2,000 sailors and the Merchant Navy lost approximately 1,500 members and 59 merchant ships. The Battle of the Atlantic was the longest and most vital battle of the Second World War.

In 1982, the Naval Officers Association of Canada (now Naval Association of Canada) played a leading role in acquiring the ship. The Canadian Naval Corvette Trust (now the Canadian Naval Memorial Trust) was established to take ownership, maintain and operate the "Last Corvette". The ship was converted back to its 1944 configuration in the 1982-1985 timeframe. **HMCS Sackville** is a National Historic Site and was designated **Canada's Naval Memorial** in 1985. Over the past three plus decades, **HMCS Sackville** has welcomed hundreds of thousands of visitors and hosted numerous naval, community and corporate events. In June of 2010 during the 100<sup>th</sup> anniversary of the RCN, Her Majesty Queen Elizabeth II, accompanied by Prince Philip, the Duke of Edinburgh, visited **HMCS Sackville** and unveiled a plaque to commemorate the Royal Visit and the significance of Canada's Naval Memorial. It was a milestone in CNMT's mission to preserve the ship in perpetuity.

The Canadian Naval Memorial Trust became a partner, in 2019, with the Maritime Museum of the Atlantic, Develop Nova Scotia and the Canadian Maritime Heritage Foundation to establish a new **Canadian Maritime Heritage District** on the Halifax waterfront that includes the Maritime Museum of the Atlantic, **HMCS Sackville**, CSS Acadia and a small craft centre. Being part of the Maritime Heritage District ensures the iconic corvette continues to serve as a national memorial and a symbol of a defining achievement of the Royal Canadian Navy during the Second World War.

*HMCS Sackville commemorates the 100,000 men and women who served in the RCN during the Second World War, the 2000 lost at sea and it honours the commitment and sacrifice of sailors*

For more information on supporting **HMCS Sackville**, please visit our website: [www.canadasnavalmemorial.ca](http://www.canadasnavalmemorial.ca) or [www.hmcssackville.ca](http://www.hmcssackville.ca)



The Canadian Naval Memorial Trust (CNMT) is dedicated to the long-term preservation and professional operation of HMCS SACKVILLE, the last corvette and Canada's Naval Memorial, for the benefit of all Canadians. Support the CNMT by becoming a member, by renewing your membership and/or by making a donation:

**Life Member:**

\_\_\_ one-time donation of \$1000 **or** \_\_\_ 10 consecutive monthly payments of \$100..... \$ \_\_\_\_\_

**Annual Member:** annual donation of \$75..... \$ \_\_\_\_\_

**Additional Donations to:**

Canadian Naval Memorial **Preservation** Fund: ..... \$ \_\_\_\_\_

**Just For The Hull Of It** Campaign..... \$ \_\_\_\_\_

Canadian Naval Memorial **Operating** Fund: .....\$ \_\_\_\_\_

In Memoriam: Name: \_\_\_\_\_ Rank: \_\_\_\_\_ Date of Death: \_\_\_\_\_ \$ \_\_\_\_\_

**Endowment** Fund – please contact the Administrator at sectreas@canadasnavalmemorial.ca for details.

**TOTAL AMOUNT: Membership + Donation: \$ \_\_\_\_\_**

NAME: \_\_\_\_\_ RANK (if appropriate) \_\_\_\_\_

ADDRESS: \_\_\_\_\_ CITY: \_\_\_\_\_ PROV: \_\_\_\_\_

Postal Code: \_\_\_\_\_ TEL: (\_\_\_\_) \_\_\_\_\_ Member # (For Renewal) \_\_\_\_\_

EMAIL: \_\_\_\_\_@\_\_\_\_\_

Visa, MasterCard, AMEX #: \_\_\_\_\_ - \_\_\_\_\_ - \_\_\_\_\_ - \_\_\_\_\_ CVC/CVV \_\_\_\_\_  
three digit # back of card

Name on Card \_\_\_\_\_ Expiry \_\_\_\_ (mm) \_\_\_\_ (yy)

I authorize the use of this credit card (initial appropriate space) to:

1. pay the above amount: Yes \_\_\_\_\_ No \_\_\_\_\_
2. to renew my membership on an annual basis in the amount of \$ \_\_\_\_\_: Yes \_\_\_\_\_ No \_\_\_\_\_
3. to pay my mess bill: Yes \_\_\_\_\_ No \_\_\_\_\_

\_\_\_\_\_ Date

\_\_\_\_\_ Signature

**Cheques:** Please make cheques payable to: Canadian Naval Memorial Trust  
 Mail Address: HMCS SACKVILLE, PO Box 99000 STN Forces, Halifax, NS B3K 5X5

**On-line payments for Memberships and Direct Donations may be made on the CNMT website:**  
[www.canadasnavalmemorial.ca](http://www.canadasnavalmemorial.ca) using VISA, M/C, AMEX or PayPal.

*Please complete the short member survey on page 2*